

Multipoint Temperature Measurement and Tank Volume Computations

TTM100



Programming and installation manual

BVS 04 ATEX E 172

Revision 1.7

14.07.2011

Construction Year see type plate

IBS BatchControl GmbH
Marie-Curie-Str. 8
50170 Kerpen
Germany

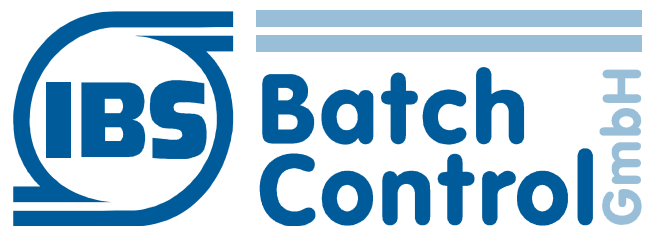

Tel.: +49 (0) 22 73 / 60 37 0
Fax.: +49 (0) 22 73 / 60 37 22
www.ibs-batchcontrol.de

1 Introduction

1.1 Table of Contents

1 Introduction.....	3
1.1 Table of Contents.....	3
1.2 Purpose of this Document.....	6
1.3 Range of Application.....	6
1.4 Scope of supply.....	6
1.5 Product liability and warranty.....	6
1.6 Definition of terms.....	7
2 User Interface.....	8
3 Service and Maintenance.....	9
3.1 Test functions.....	9
3.2 Calibration.....	9
3.2.1 Pt100 Input.....	9
3.2.2 4-20 mA Analogue Inputs.....	9
3.2.3 Internal Temperature.....	9
3.3 Trouble Shooting.....	9
3.3.1 Pt100 Errors.....	9
3.3.2 Analogue Input Errors.....	10
3.3.3 Configuration and Parameter Errors.....	10
3.3.4 RS485 Communication.....	10
3.3.5 HART Communication.....	11
3.4 Basic Servicing.....	11
3.5 Fault Clearing.....	11
4 Technical Data.....	12
4.1 Input Characteristics.....	12
4.1.1 TTM100 A.....	12
Pt100 Inputs.....	12
Temperature Probe.....	12
Analogue Inputs.....	12
Connections.....	12
Approvals.....	13
Enclosure.....	13
4.1.2 TTM100 B.....	13
Analogue Inputs.....	13
Relay Output.....	13
Interfaces.....	13
Power Supply.....	13
Ambient conditions.....	14
Local Display.....	14
Connections.....	14
Approvals.....	14
Enclosure.....	14
4.2 Terminal connections.....	15
4.2.1 TTM100 A.....	15
4.2.2 TTM100 B.....	16
5 Installation Guidelines.....	17
5.1 Tank installation.....	17

6	Measuring Principle	18
6.1	Level measurement	18
6.1.1	BM70/100	18
6.1.2	OPTIWAVE 7300C / 1300C	18
6.1.3	Other level sources	18
6.1.4	TTM100 Level reading	18
6.2	Temperature measurement	19
6.2.1	Multipoint Temperature probe	19
6.2.2	Single spot temperatures	20
6.3	Pressure measurement	20
6.3.1	Pressure transmitters	20
7	Calculations	21
7.1	Calculation Overview	21
7.1.1	Tank calculations	21
7.2	Average Temperatures	25
7.2.1	Height weighted averages	25
7.2.2	Volume weighted averages	26
7.3	Level	27
7.3.1	Level instrument selection	27
7.3.2	Level correction for stilling well or tank height expansion	27
7.4	Pressure	28
7.4.1	Pressure selection	28
7.4.2	Average pressure	28
7.5	Observed Volume	29
7.5.1	Strapping table	29
7.5.2	Volume correction for shell expansion due to temperature	29
7.5.3	Volume correction for floating roofs	30
7.5.4	Bulging correction	31
7.5.5	Observed Volume	31
7.6	Actual Density	32
7.6.1	From level and pressure measurement	32
7.6.2	From level and pressure measurement	33
7.7	Standard Density	33
7.7.1	API D2540	33
7.7.2	Standard Volume and Mass	35
8	Alarms	36
8.1	Instrument alarms	36
8.2	Input errors	37
8.2.1	Pt100 errors	37
8.2.2	Analogue input errors	37
8.3	Initialisation errors	38
8.4	Calculation errors	38
8.4.1	Level calculation errors	38
8.4.2	Temperature calculation errors	39
8.4.3	Pressure calculation errors	39
8.4.4	Strapping table calculation errors	39
8.4.5	Floating roof calculation errors	40
8.4.6	Density calculation errors	40
8.4.7	API D2540 calculation errors	40
8.5	Limit Alarms	40
9	Miscellaneous Functionality	42
9.1	Input filtering	42
9.2	Alarm Masking and Relay Outputs	42
9.3	Internal Temperature Control	42
9.4	Level Instrument Configuration	42
9.5	Diagnostics	43

10 Configuration	45
10.1 General	45
10.2 System Parameters	45
10.2.1 Input filtering	45
10.2.2 Communication settings	45
10.2.3 Internal temperature control	46
10.2.4 Display configuration	46
10.2.5 Communication line termination resistor	49
10.2.6 Sensor break limit	49
10.2.7 Analogue input scaling	49
10.3 Tank parameters	50
10.3.1 Tank dimensions	50
10.3.2 Other tank related parameters	50
10.4 Alarm Limits	51
10.5 System Configuration	51
10.5.1 Probe dimensions	51
10.5.2 Input assignment	52
10.5.3 HART devices	53
10.5.4 Pressure measurement	54
10.5.5 Tank related calculations configuration	54
10.5.6 Product related calculations configuration	54
10.5.7 Alarm masking	55
11 Ordering Information	57
A Communication	58
A.1 BM70/BM100 Krohne Protocol	58
A.2 Modbus Protocol	58
A.2.1 General	58
A.2.2 Calibration	59
A.2.3 Configuration	61
A.2.4 Parameters	66
A.2.5 Measured data	68
A.2.6 Calculated data	69
A.2.7 Alarms	70
A.2.8 Diagnostics	71
B Housing Dimensions	79
C Atex Approval	82

1.2 Purpose of this Document

This document contains all relevant information concerning the TTM100 for operators, process engineers or service and maintenance engineers.

1.3 Range of Application

The TTM100 can be used in a wide range of measurement applications, but is specifically designed as a data acquisition and computing device for storage tanks metering systems. The configuration options are chosen to cover most tank management applications in the petrochemical industry.

1.4 Scope of supply

The TTM100 is supplied as a set of hardware, software and documentation consisting of:

- TTM100 A (optional)
 - Electronics (optional)
 - Temperature probe (optional)
- TTM100 B
- User Manual
- TTM Monitor configuration tool.
- Calibration report (optional)
- Material certificates (optional)
- Certificate of origin (optional)
- ATEX certificate (optional)
- EMC Approval 89/336/EG EN61326 + EN61326/A1 (optional)

1.5 Product liability and warranty

The TTM100A is designed for multipoint temperature measurement and additional tank measurement data acquisition.

The TTM100B is designed for tank measurement data acquisition and computation.

Special codes and regulations apply to its use in hazardous areas

Responsibility as to suitability and intended use of this instrument rests solely with the user.

Improper installation and operation may lead to loss of warranty.

In addition, the "General conditions of sale", found on the back of the invoice and forming the basis of the purchasing contract, are applicable.

1.6 Definition of terms

Term	Description
ADC	Analog to Digital Converter
BM100	Krohne Level instrument
BM70	Krohne Level instrument
Calibration	Adjusting measurement setting to meet specifications
Checksum	Calculated value over an amount of data to check data validity
Configuration	Setting parameters that influence the behaviour of the instrument
CPU	Central Processing Unit
Download	Sending data from a computer to the instrument
EEPROM	Electrical Erasable Programmable Read Only Memory
EPROM	Erasable Programmable Read Only Memory
HART	Communication protocol over 4-20 mA signal
Initialisation	First sequence after start up
Interface	Separation level between two liquids
Modbus	Data communication protocol
OPTIFLEX	Krohne Level instrument
OPTIWAVE	Krohne Level instrument
Pt100	Temperature element
RAM	Random Access Memory
RS485	Hardware standard for data communication
Stilling well	Vertical pipe used for measurement equipment
Supervisory computer	Computer meant for HMI for operators
TTM100	Temperature measurement device and tank computer
TTM100A	TTM100 part connected to the temperature probe
TTM100B	TTM100 part with embedded computer
VCO	Voltage Controlled Oscillator

2 User Interface

The TTM100 is configurable via a serial link; there are no buttons on the instrument itself to configure it.

The TTM100 B is equipped with a display to show required data in the tank field. Physically there are 2 lines with 16 characters. 20 lines with 16 characters can be configured to show text and data. The display will scroll on a configurable time base when more than 2 lines are configured.

The display can be configured to show text and calculated and measured values in a configurable format.

3 Service and Maintenance

3.1 Test functions

The instrument performs a parameter check during start up. An initialisation error is set when the checksum over a parameter set is not right.

The cause of an initialisation error can be:

- No parameters downloaded. Happens when the TTM100 is switched on the first time.
- New software version download into the TTM100

The initialisation errors will disappear after downloading all parameters and configuration.

3.2 Calibration

3.2.1 Pt100 Input

Standard Pt100 (385) curves are implemented in the software for each Pt100 input.

A 2 point calibration with certified calibrator is done for each input to get the best fit of the curve.

Offset parameters can be used to correct for the inaccuracy of a Pt100 elements.

3.2.2 4-20 mA Analogue Inputs

A 2 point calibration with certified calibrator is done for each analogue input.

3.2.3 Internal Temperature

The internal temperature of the instrument is measured. This temperature can be used to monitor the instrument and to control an internal heater for use in cold environments.

3.3 Trouble Shooting

3.3.1 Pt100 Errors

Temperature elements are connected as 2 loops of 8 Pt100's each.

A broken connection or element will result in measuring errors because there is no current in the loop, the electronics will detect this and raise loop current alarm. All measurements in the same loop are faulty.

An open loop alarm will be raised for a specific Pt100 when the measured temperature increases a configurable error limit. The resistance became too high and the Pt100 is likely to be damaged.

A short circuit alarm will be raised for a specific Pt100 when the measured temperature decreases a configurable error limit. The resistance became too low and the Pt100 is likely to be damaged or there is a real short circuit in the wiring.

3.3.2 Analogue Input Errors

Analogue inputs measure current in the range of 4-20 mA or 0-20 mA. The measured current is compared to configurable error limits to detect open circuits and short circuits. Alarms are raised when inputs are in error state.

3.3.3 Configuration and Parameter Errors

The TTM100 is a flexible instrument and therefore there are many configuration options and parameters available. Most parameters and configuration options are set during commissioning or updated by specialised engineers when there are tank installation changes. Using the TTM Monitor is no guarantee for right configuration; the user is responsible to fill in a configuration that complies with the tank dimensions, measurement setup and the desired calculations.

Process limit alarm parameters are subject to change more frequently than other parameters. Changing these parameters will not affect measurement and calculation results. It is likely that these parameters are changeable by operators via a supervisory system. The TTM100 will check for restrictions on alarm limit parameters and raise an alarm if the settings are invalid.

3.3.4 RS485 Communication

The TTM100 has 2 Modbus communication ports and one port using the Krohne protocol to connect to BM100 and BM70 level instruments. A TTM Monitor program is used to configure and check the instrument, it uses the Modbus protocol.

The TTM Monitor program is an easy to use program to test the TTM100 communication.

Causes of communication failures are in general:

- Wrong selection of the communication port of the PC where the TTM Monitor runs.
Try another one, easy to select in the TTM Monitor program.
- Mismatch in baud rate between TTM Monitor program and TTM100.
Try another one, easy to select in the TTM Monitor program. Default setting in the TTM100 is 9600 baud.
- Wrong Device ID selected.
Try another one, easy to select in the TTM Monitor program. Default device ID in the TTM100 is 1.
- Wrong RS485 connection, e.g. crossed wires.
- RS485 load too high, too many instruments or too many instruments with termination resistors. Make a one to one connection with the instrument under test. Make sure that termination is only set at the ends of the line. Maximum amount of instruments on 1 line without repeaters is 32.
- Bad RS485 line
Maximum length without repeaters is 1200m. It must be a twisted pair type to minimize disturbance and the right impedance to minimize distortion.

3.3.5 HART Communication

The TTM100 can be equipped with HART communication to connect pressure transmitters or level instruments with HART communication.

Possible causes of failure are:

- Wrong Manufacturer code
Check with TTM Monitor
- Wrong Device type code
Check with TTM Monitor
- Wrong Device ID
Check with TTM Monitor
- Wrong configuration
Assignment configuration parameters must be set right. (set to 9 for HART on Analogue input 1 and 10 for HART on Analogue input 2)
- Wrong connections HART communication is not working.
Check the electrical circuit

3.4 Basic Servicing

There is no basic servicing required after commissioning other than checking the connections and the internal temperature every now and then.

3.5 Fault Clearing

An extensive set of errors, alarms and status flags are available in the Modbus alarm block. The supervisory computer uses this block to collect alarms. Checking the raised alarms on the supervisory computer is the first thing to look for to find what causes a problem.

The TTM100 has the option to mask irrelevant alarms in the Modbus alarm block. The Modbus diagnostics block contains all unmasked alarms and intermediate calculation results. This is the next thing to look for to find what causes a problem. Checking diagnostics might not be implemented in a supervisory computer and must be done with the TTM Monitor configuration tool.

Other things to check are of course all parameter and configuration settings and the installation itself.

4 Technical Data

4.1 Input Characteristics

4.1.1 TTM100 A

Pt100 Inputs

Maximum 16 Pt100 inputs divided in 2 groups of 8 4-Wire Pt100's connected in series.

Measurement range:	-50°C to + 180°C (-58°F to+356°F)
Standard Accuracy:	better than ± 0.2 K over the total measurement range
Optional Accuracy:	better than ± 0.1 K over the total measurement range
Classification Area Safety:	Ex ib

Temperature Probe

Temperature sensors	Max. 16x Pt100,
Standard:	Class A
Option:	up to Class A 1/10
Length	Max. 40 m (131 ft), flexible version

Max. allowable operating pressure

Standard:	12 bar (174 psig)
Option:	25 bar (362 psig)

Sheath probe Stainless Steel 316L

Analogue Inputs

Four times 4-20mA active analogue inputs

Measurement range:	4-20 mA
Accuracy:	better than 0.1% over the full range.
Classification Area Safety:	Ex ib

Connections

M20 Cable glands	
Standard:	Nickel plated brass
Option:	Stainless steel
Probe connection	Minimum flange size: 1 ½" ANSI 150 lbs

4 Technical Data

Ambient conditions

Standard: -20°C to +60°C (-13°F to+ 140°F)
Option with heater: -40°C to +60°C (-40°F to+ 140°F)

Local Display

Dot Matrix LCD Display with 2 x 16 characters

Connections

M20 Cable glands (option)

Standard: Nickel plated brass for 6 to 12 mm cable
Option: Stainless steel

Approvals

ATEX approval: II 2 G Ex d[ib] IIC T4 Gb for TTM 100 B
EMC approval: 89/336/EG EN61326 + EN61326/A1

Enclosure

Housing Aluminium with electrostatic powder coating
IP 65

4.2 Terminal connections

4.2.1 TTM100 A



Terminal	Description	Terminal	Description	Terminal	Description
KLA1	Pt100 8 (-)	KLB1	Pt100 16 (-)	20	AI 8 (+)
KLA2	Pt100 8 (+)	KLB2	Pt100 16 (+)	21	AI 8 (-)
KLA3	Pt100 7 (-)	KLB3	Pt100 15 (-)	22	AI 7 (+)
KLA4	Pt100 7 (+)	KLB4	Pt100 15 (+)	23	AI 7 (-)
KLA5	Pt100 6 (-)	KLB5	Pt100 14 (-)		
KLA6	Pt100 6 (+)	KLB6	Pt100 14 (+)	24	AI 6 (+)
KLA7	Pt100 5 (-)	KLB7	Pt100 13 (-)	25	AI 6 (-)
KLA8	Pt100 5 (+)	KLB8	Pt100 13 (+)	26	AI 5 (+)
KLA9	Pt100 4 (-)	KLB9	Pt100 12 (-)	27	AI 5 (-)
KLA10	Pt100 4 (+)	KLB10	Pt100 12 (+)		
KLA11	Pt100 3 (-)	KLB11	Pt100 11 (-)	28	+Us1
KLA12	Pt100 3 (+)	KLB12	Pt100 11 (+)	29	GND
KLA13	Pt100 2 (-)	KLB13	Pt100 10 (-)	30	+Us2
KLA14	Pt100 2 (+)	KLB14	Pt100 10 (+)	31	TxD
KLA15	Pt100 1 (-)	KLB15	Pt100 9 (-)		
KLA16	Pt100 1 (+)	KLB16	Pt100 9 (+)		
KLA17	Supply (+)	KLB17	Supply (+)		
KLA18	Supply (-)	KLB18	Supply (-)		

4.2.2 TTM100 B



Ex d

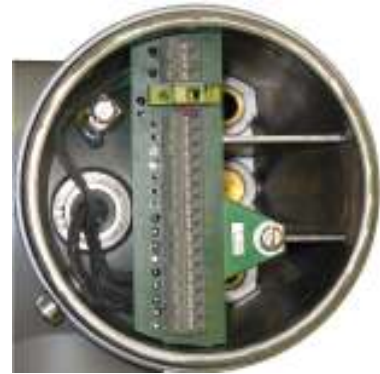

Ex i



Ex d part			
Terminal	Description	Terminal	Description
1	RS485 Comport 1 (+)	13	Relay 1
2	RS485 Comport 1 (-)	14	Relay 1
3	RS485 Comport 2 (+)	15	Relay 2
4	RS485 Comport 2 (-)	16	Relay 2
5	RS485 Comport 3 (+)		
6	RS485 Comport 3 (-)		
7	AI 1 (-)		
8	AI 2 (-)		
9	AI 1/2 (+)		
10	AI 3 (-)	17	PE
11	AI 4 (-)	18	115 / 230 VAC, 24VDC
12	AI 3/4 (+)	19	115 / 230 VAC, 24VDC

Ex i part	
Terminal	Description
1	+Us1
2	0 V
3	+Us2
4	RxD

5 Installation Guidelines

5.1 Tank installation

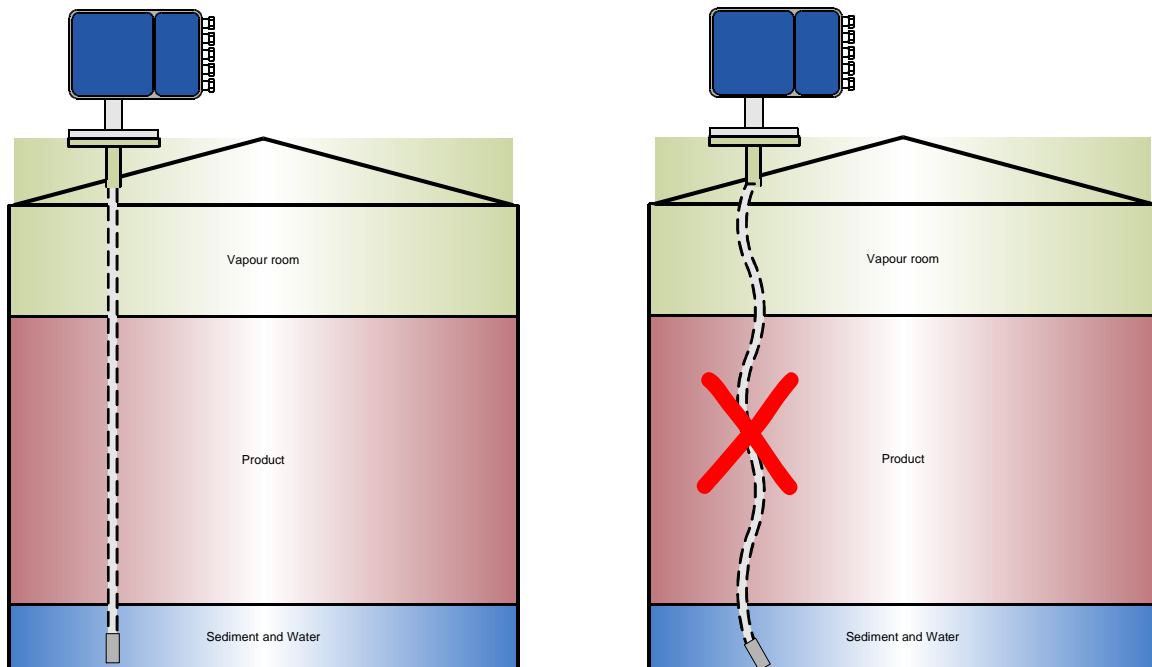

The counterweight should not touch the bottom of the tank to let the probe hang straight in the tank. The temperatures measured by a Pt100 in the probe should represent the average temperature of the whole area at the height of the Pt100. The ambient temperature might have too much influence when the probe is mounted close to the tank side

6 Measuring Principle

6.1 Level measurement

6.1.1 BM70/100

The BM70 Radar instrument measures the distance to a liquid surface by sending a frequency sweep radio wave and compare it with the reflection from the liquid surface. It calculates the distance from the frequency spectrum. The advantage of a BM70 compared to a BM100 is that there is no physical contact with the liquid.

The BM100 instrument sends an electromagnetic pulse over a wire or rod dipped into the liquid. A pulse is reflected from the liquid surface. The distance to the liquid surface is calculated from the time delay of the reflected pulse. Because the wire is hanging in the liquid it can also measure a separation of two liquids as long as there is a clear separation and the dielectrical constant differs enough. The separation of two liquids is called 'interface'. The advantage of a BM100 is the capability to measure the interface between oil and water in a storage tank.

The level and interface are measured by a BM70 or BM100 Krohne instrument. These instruments are equipped with an RS485 serial link and a Krohne protocol.

6.1.2 OPTIWAVE 7300C / 1300C

The OPTIWAVE 7300 C is a new radar instrument based on the same principles as a BM70.

The OPTIFLEX 1300 C is a new instrument based on the same principles as a BM100.

The instrument has a 4 – 20mA output with HART communication protocol.

6.1.3 Other level sources

Levels from other measurement devices can be used via 4-20mA analogue inputs or via Modbus from a supervisory computer.

6.1.4 TTM100 Level reading

The TTM100 is capable of handling two level instruments. One instrument is used as primary level instrument and a secondary level instrument can be used as fallback when the primary instrument fails. The level and interface readings can come from different sources, e.g. a BM100 instrument for the primary measurement and a level reading from an external system via Modbus.

The primary readings are used by the TTM100 under normal conditions. The secondary readings are used as fallback when there are alarms that indicate an unreliable reading of the primary level and/or interface.

The BM70 and BM100 instruments are connected to comm2 of the TTM100. Instrument errors, alarms and status flags from the instruments are used to determine the reliability of the instrument measurement. The errors, alarms and status flags from the BM70 and BM100 instruments are transferred to the Modbus communication for monitoring reasons.

The OPTIWAVE and OPTIFLEX instruments are connected via an analogue input with HART protocol. The operation is similar to the BM70 and BM100 instruments.

6.2 Temperature measurement

6.2.1 Multipoint Temperature probe

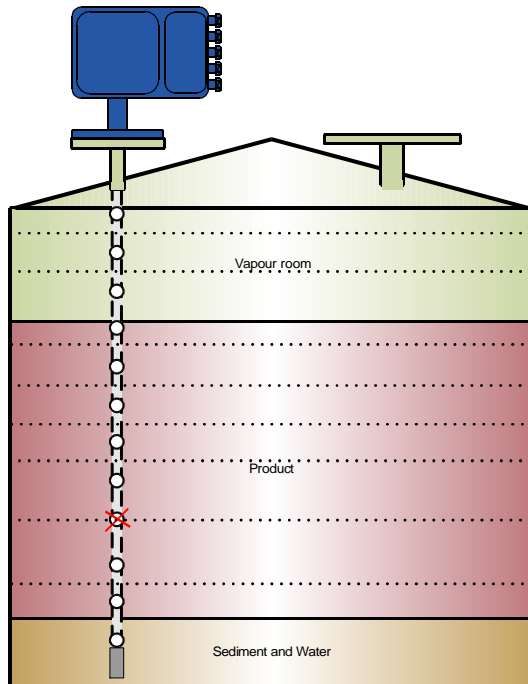

A Multipoint temperature probe is used to measure the average temperatures with the highest achievable accuracy. A tank contains typically 3 compartments, sediment and water, stored product and vapour room. Up to 16 temperature spots can be measured. The locations of the Pt100's in the probe can be tailored to customer needs.

Each measured temperature represents a part or layer inside a tank. This is based on the assumption that the temperature only varies by height. This profile will be close to a real situation when the tank is stabilised, movements inside the tank are minimal and the influence of outside weather conditions are minimal.

Weight factors for each Pt100 are calculated because spaces between Pt100's are not necessarily equal, height and volume relation is not always linear, Pt100's can fail and the interface and level can vary.

Linear weight factors are calculated by the height of the layers and used for stilling well and shell expansion correction purposes. Volume weighted averages are calculated by the volume of the layers and are used for volume correction factors. (VCF)

Relatively large differences between the vapour and the liquid temperature can occur within a tank. A Pt100 element located just above the liquid surface can show a value close to the liquid temperature due to relatively high heat conductivity in the steel hose of the temperature probe. This Pt100 does not represent the vapour temperature and should not be taken in account to calculate the average vapour temperatures. A dead band around the level in which Pt100's are not used for average calculation prevents these measurement errors.

The dead band limits are configurable.

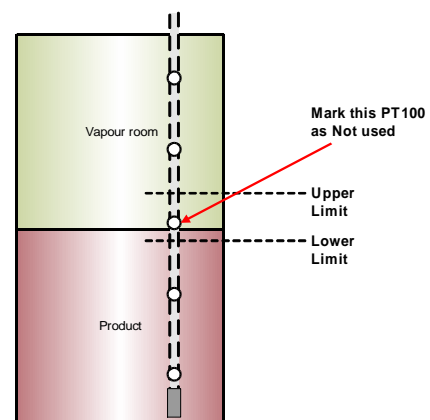

6.2.2 Single spot temperatures

Single spot temperatures can be connected and configured as a 4-20 mA inputs for the water, product and vapour part.

Connecting a Pt100 a single spot temperature to a Pt100 input is another possibility. Note that the Pt100 inputs are meant for a temperature probe; the right height value must be configured to make sure that the used Pt100 always calculates to the right average.

Average temperatures from external sources can be used via the Modbus link.

6.3 Pressure measurement

6.3.1 Pressure transmitters

The TTM100 is able to read Yokogawa pressure transmitters (type EJA 430) via HART communication on analogue input 1 or 2.

Other transmitters with 4-20mA signals can also be used.

Pressures from external sources can be used via the Modbus link.

Pressures can be measured as an absolute pressure value or as a differential pressure against atmospheric pressure. A configuration setting is provided to set the used pressure transmitter type.

The average pressure calculated by the TTM100 is always against atmospheric conditions.

(=1,01325 bara as standard atmospheric pressure when absolute pressure measurement is used)

7 Calculations

7.1 Calculation Overview

Calculations are divided in tank related calculations and product related calculations.

Tank calculations depend on level and temperature measurements and a set of parameters describing the physical dimensions of the tank. The result of the tank related calculations is an observed volume under actual temperature and pressure conditions.

The product calculations will result in a product volume under reference conditions and the product Mass. Product calculations implemented in the TTM100 according to API standards.

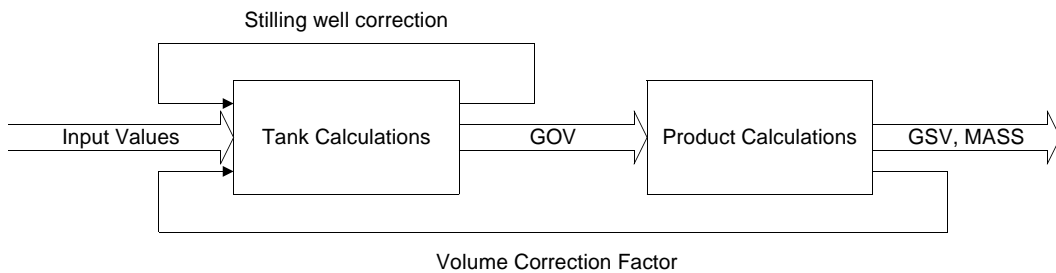

Levels are corrected for stilling well expansion due to temperature. Average temperatures are used to calculate the corrections. Average temperatures are calculated using the corrected level. This explains the iterative stilling well loop in the drawing above.

The Volume Correction Factor (VCF) is a result the product calculations and it is used in the tank calculations to calculate a floating roof correction when required.

7.1.1 Tank calculations

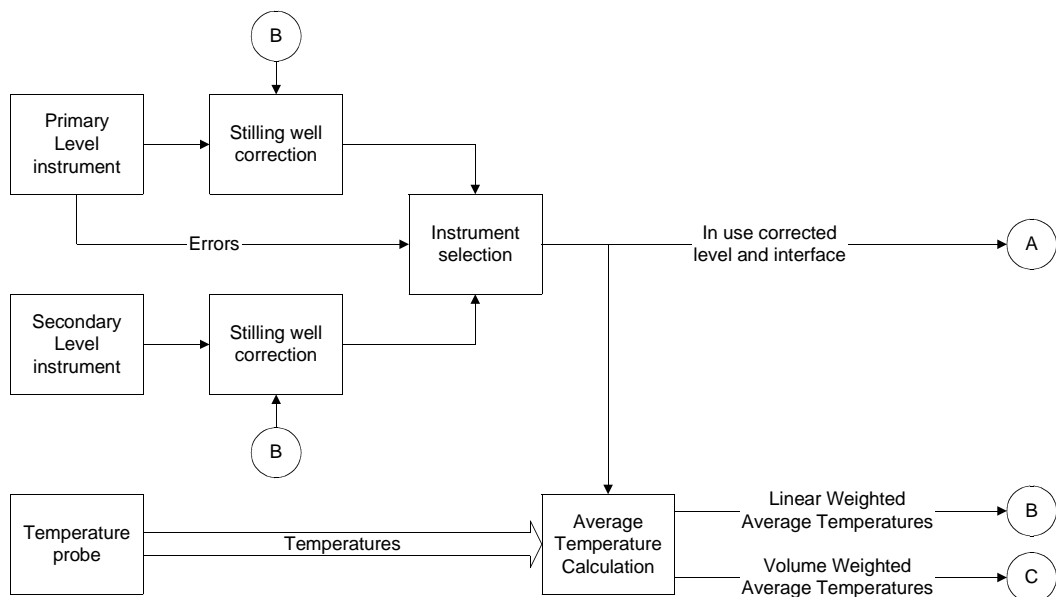

The TTM100 has the option to connect two level instruments. The error status of the primary instrument determines which instrument is used for level/interface measurement. It is possible that one instrument measures level and the other interface. The temperature probe contains up to 16 Pt100 elements at different heights to measure the temperature. The linear weighted average temperatures are temperatures weighted by their distances in height. These average temperatures are used for the stilling well expansion correction and the shell expansion correction (see below) assuming that the average temperature on the tank shell has the same temperature profile in height as the products inside the tank.

The relation between the height and the volume depends on the tank shape and is not necessarily linear. A volume weighted average temperature is needed to calculate the volume under reference conditions, see product calculations.

The volumes in the tank are calculated with the corrected heights and a strapping table. Next step is a correction for the shell expansion due temperature. The weight of a floating roof causes a level offset in the stilling well. The floating roof correction is a volume correction based on the roof weight. A bulging correction factor can be used to correct for shell deformation of the tank.

All measured values can come from an instrument or as an override value via Modbus and all corrections are optional. The configuration determines the source of measurement values and which corrections are performed or not.

The configuration settings for tank calculations with two level instruments, a temperature probe, a floating roof tank and all correction activated are i. e.:

bm_stat	0x0A02	Both primary and secondary level instruments are BM100's communicating with 9600 baud.
bm_p_adr	1	Primary BM100 address
bm_s_adr	2	Secondary BM100 address
ASTAVV	13	Average vapour temp. calculated from temperature probe
ASTAVP	13	Average product temp. calculated from temperature probe
ASTAVW	13	Average water temp. calculated from temperature probe
ASLVL1	11	Primary level from level instrument
ASINT1	11	Primary interface from level instrument
ASLVL2	11	Secondary level from level instrument
ASINT2	11	Secondary interface from level instrument
Tanktype	1	Floating roof
FRCtype	1	Floating roof correction
STWCtype	1	Stilling well correction activated
SEtype	1	Tank shell correction activated
BCtype	1	Bulging correction activated

Detailed information about configuration is found in chapter Configuration page 45.

Different options are available for product calculations to cover most applications.

Actual density can be calculated from pressure when accurate pressure measurement is available. The reference density can be calculated from actual density, actual temperature and pressure according to API D2540 standards.

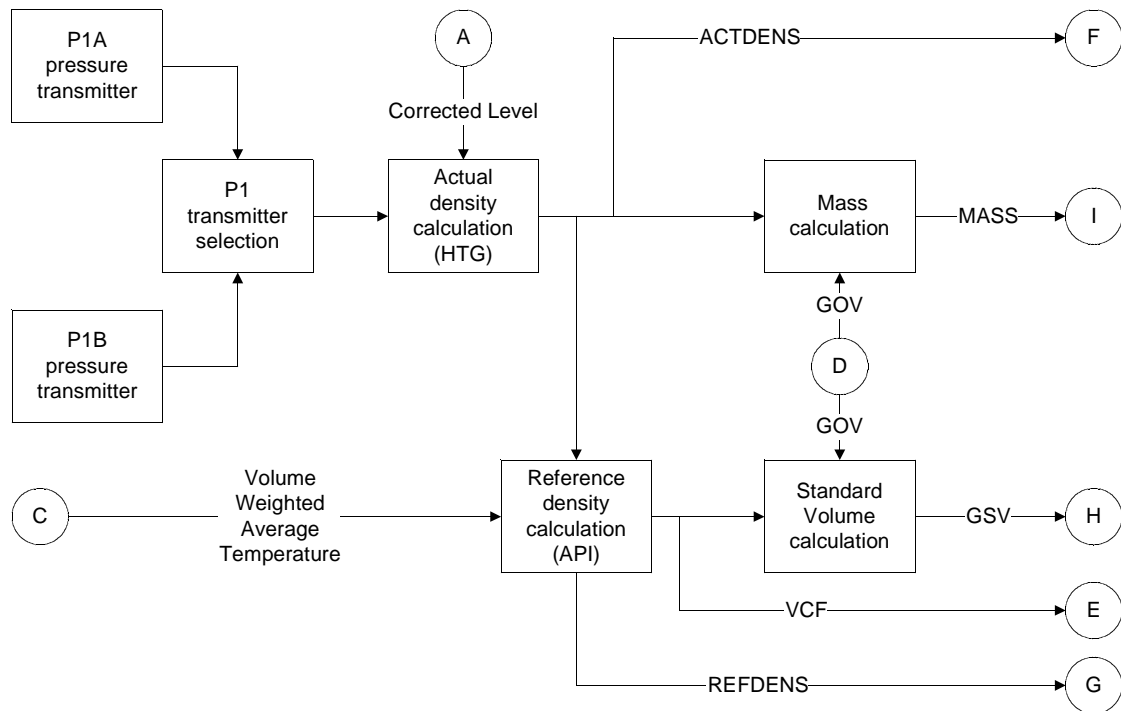

Configuration settings for this option are i. e.:

ASP1A	1	Liquid pressure P1A on analogue input 1
ASP1B	2	Liquid pressure P1B on analogue input 2
ASP3	3	Vapour pressure P3 on analogue input 3
ASACTD	12	Calculated from pressure inputs
ASREFD	0	No input value available
VCftype	2	Temperature and pressure correction

The reference density can come via Modbus from an external source. The API calculation is no longer needed in this alternative case.

The same configuration settings are used except for:

ASREFD	14	Modbus override
--------	----	-----------------

The next diagram shows the calculations

7 Calculations

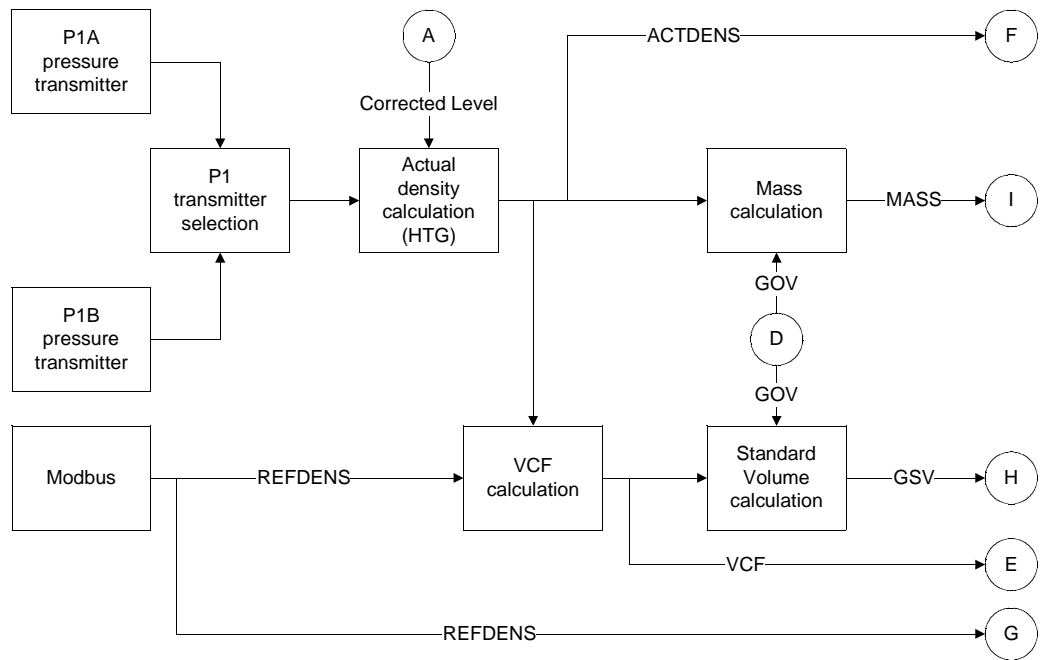

In many cases pressure readings are not available. Either reference density or actual density must be available to calculate the volume under reference conditions and the mass. It is most likely that a reference density is made available via Modbus. The next diagram shows the calculation for this case.

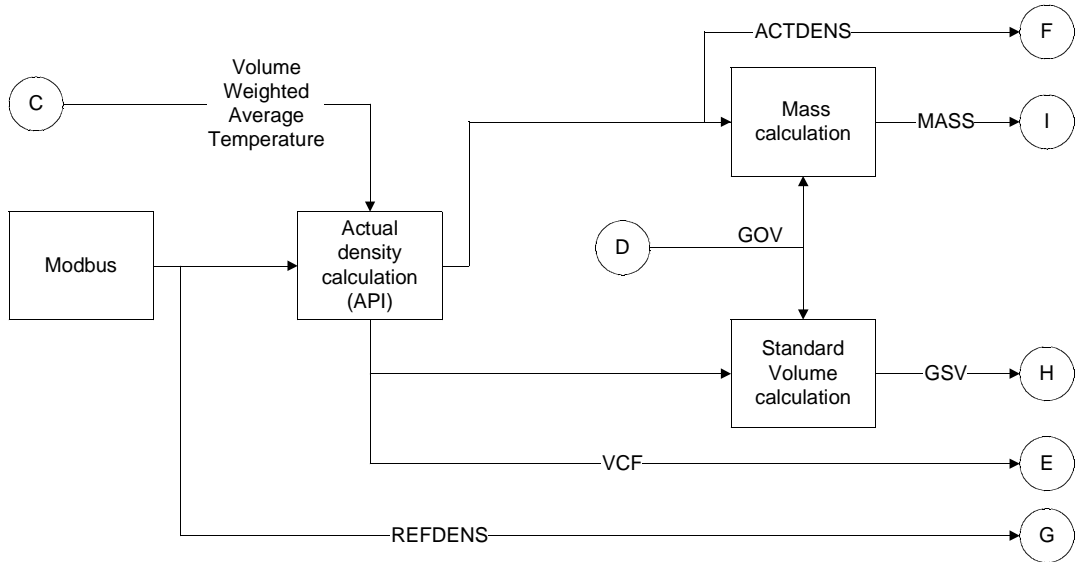

Configuration settings for this option are i. e.:

ASACTD	0	Calculated from pressure inputs
ASREFD	14	No input value available
VCFtype	1	Only temperature correction
HTempMethod	2	External Reference Density; Actual density calculated

The alternative to previous set up is that the actual density is available.

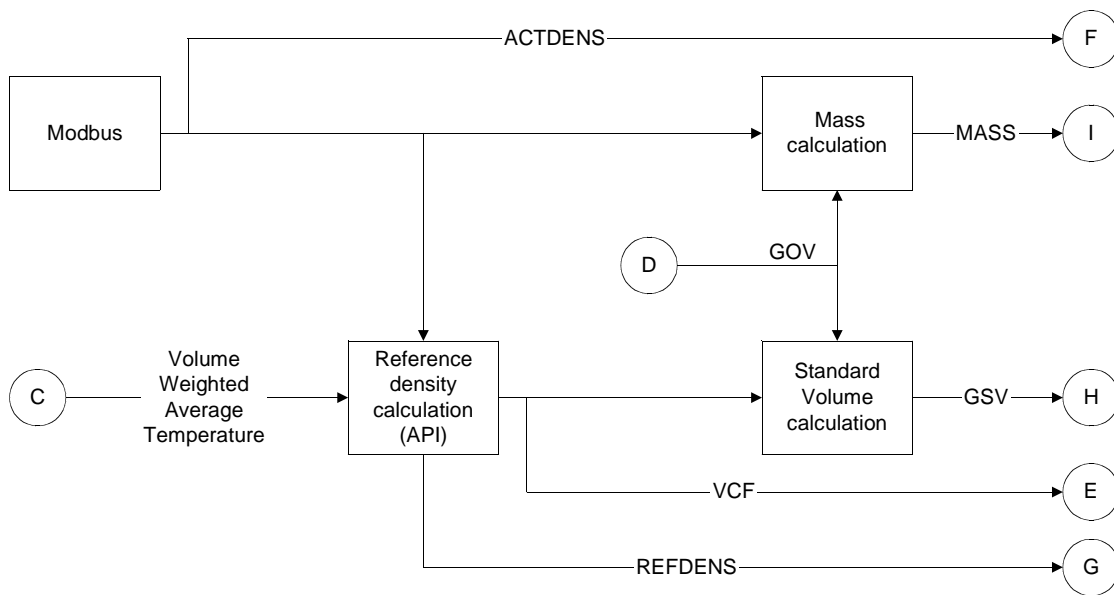

Configuration settings for this option are i. e.:

ASACTD	14	Calculated from pressure inputs
ASREFD	0	No input value available
VCFtype	1	Only temperature correction

Notes:

The four calculation principles will cover most applications. A supervisory computer can perform product calculations in special cases or for special products where the API D2540 calculation doesn't fit.

Apart from the configuration settings mentioned there are more options to choose from. These options can have an effect on the results but do not really change the sequence of calculations. The product calculation always follows the principle of one of the four alternatives.

7.2 Average Temperatures

7.2.1 Height weighted averages

A tank is built up in 3 compartments, sediment and water, stored product and a vapour room. Each compartment is built up in layers for each input. This is based on an assumed temperature profile in the tank, where the temperature only varies by height.

It is determined for each used Pt100 in which compartment it is located using interface and level readings.

For each compartment a weighted average by height is calculated:

$$T_{average} = \frac{\sum (LayerheightTX * ReadingTX)}{\sum (LayerheightTX)}$$

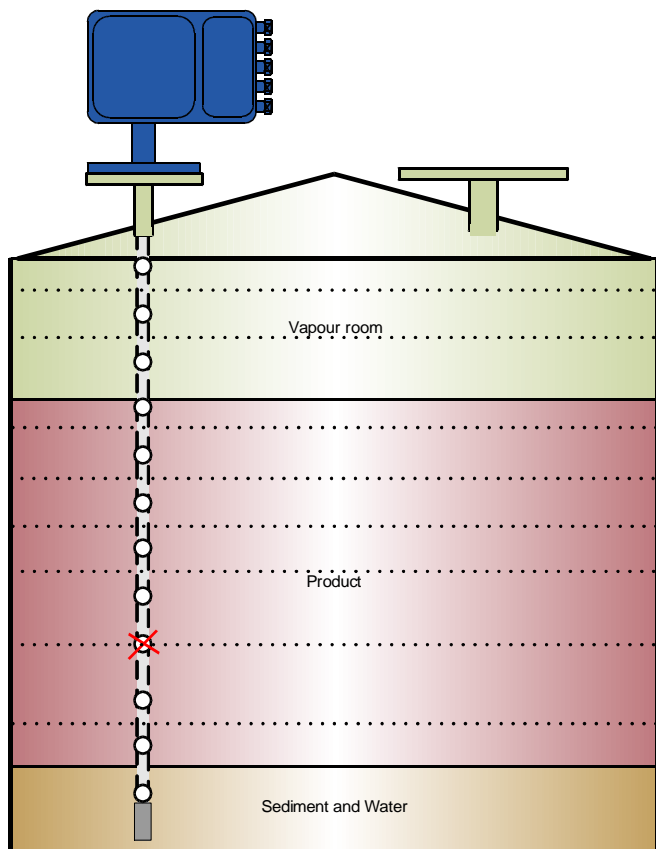

Layer height boundaries are:

- the bottom of the tank,
- the interface level,
- the top of the tank,
- when 2 or more elements are within the same compartment layer boundaries are in the middle of the used Pt100 locations.

Pt100's within the dead band are not used.

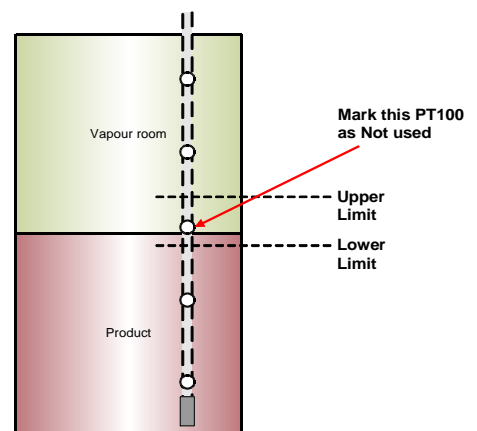

Calculated height (linear) weighted temperature averages are:

- | | |
|----------|-------------------------|
| TAWATERL | Sediment and water part |
| TAVPRODL | Stored product part |
| TAVVAPL | Vapour room |

7.2.2 Volume weighted averages

Volume weighted averages are calculated in a similar way. The difference is in the weighing of the reading, instead of the layer heights the layer volumes are used. The volumes are calculated from a strapping table.

$$T_{average} = \frac{\sum(LayervolumeTX * ReadingTX)}{\sum(LayervolumeTX)}$$

Calculated volume weighted temperature averages are:

- | | |
|---------|-------------------------|
| TAWATER | Sediment and water part |
| TAVPROD | Stored product part |
| TAVVAP | Vapour room |

Note:

The height weighted and volume weighted averages are the same for ideal vertical cylindrical tanks. Difference are found when the volume – height relation is not linear.

7.3 Level

7.3.1 Level instrument selection

The readings from the primary instrument are used in normal operation.

The secondary instrument takes over when the readings of the primary instrument are not reliable and the readings from the secondary instruments are reliable.

The reliability depends on the communication status and instrument alarms. The following alarms result in unreliable measurements and are therefore switch-over criteria:

BM70 BM100

Hardware error

- CPU error (NN)
- EPROM error (checksum)
- RAM error (write/read check)
- Interrupt error (NN)
- Counter/timer error (NN)
- EEPROM error

General error

- No signal
- No peak
- Microwave error
- Current output error (Status)
- Switch output error(Status)

Hardware error (general flag)

- Fatal Error (general flag)
- Microwave flag set
- Integrator characteristic not rising
- VCO range
- Sweep not reached
- Voltage increase too high

Hardware error

- ADC reference error
- ROM Error
- RAM Error
- EEPROM Factory Error

EEPROM User Error

- Signal error
- Microwave Error
- No End Of Scan Pulse Error
- No Reference Pulse Error
- No Level Pulse Error
- No Interface Pulse Error¹

Marker set

- No Reference pulse
- No Level pulse
- Level frozen
- No Interface pulse¹
- Interface frozen¹
- Communication Error

¹) Only when Interface measurement is applied.

7.3.2 Level correction for stilling well or tank height expansion

The height of the mounted level instrument varies due to temperature variations in the stilling well. The expansion of the stilling well is calculated based on the 3 compartments in the tank.

The correction factors are:

$$CT_{\text{vapour}} = 1 + STWEC * (TAVVAPL - REFTEMPSTWEC)$$

$$CT_{\text{liquid}} = 1 + STWEC * (TAVPRODL - REFTEMPSTWEC)$$

$$CT_{\text{water}} = 1 + STWEC * (TAVWATERL - REFTEMPSTWEC)$$

With :

STWEC Linear material expansion coefficient of the stilling well.

REFTEMPSTWEC Reference temperature for the nominal stilling well height.

A height correction is calculated for both primary and secondary level instrument.

$$dH_{STW} = CT_{\text{water}} * Interface_n + CT_{\text{liquid}} * (Level_n - Interface_n) + CT_{\text{water}} * (H_{\text{stwell}} - Level_n) - H_{\text{stwell}}$$

With :

H_{stwell} Nominal stilling well height.

The corrected levels and interfaces are:

$$Level_{n+1} = Level_n + dH_{STW}$$

$$Interface_{n+1} = Interface_n + dH_{STW}$$

7.4 Pressure

7.4.1 Pressure selection

Accurate pressure measurement is needed when the TTM 100 is configured to calculate actual density from pressure instruments.

Two pressure transmitters with different measurement ranges can be mounted just above the interface to provide accurate pressure measurement when the tank is full and when the tank is almost empty. P1A is the wide range pressure transmitter, P1B with a small range.

The P1B reading is used when the pressure of P1A is within the range of the P1B. If not P1A is used.

Switch over levels are configurable.

7.4.2 Average pressure

The average pressure of the product part in the tank can be used to calculate a volume correction factor for pressure. The TTM100 can calculate an average pressure, although for many applications the correction for pressure is negligible.

The average pressure of the liquid in the tank is :

IF *PressType* = "differential" THEN // measured against atmospheric pressure

$$PAVPROD = \frac{P1 + P3}{2}$$

ELSE // PressType = "absolute"

$$PAVPROD = \frac{P1 + P3}{2} - 101.325$$

With:

P1 In use pressure from P1A and P1B near the bottom of the product part.
 P3 Pressure in the vapour room.

PAVPROD resembles the differential pressure against atmospheric conditions in kPa.

7.5 Observed Volume

7.5.1 Strapping table

A strapping table with up to 2000 points can be loaded into the TTM100. Volumes are calculated by a linear interpolation method.

$$V_{vapour} = V_{tank} - Strappingvolume_{Level}$$

$$V_{product} = Strappingvolume_{Level} - Strappingvolume_{Interface}$$

$$V_{water} = Strappingvolume_{Interface}$$

With:

V_{tank} Total tank Volume

7.5.2 Volume correction for shell expansion due to temperature

The volumes calculated from the strapping table have to be corrected for the temperature expansion of the tank shell material. The sediment and water part, the product part and the vapour room can have different temperatures and therefore different expansion factors.

The next formula is used to calculate the expansion factors for all 3 compartments:

$$dT = T_{Average} - REFTEMP_{SEC}$$

$$F_{therm} = 1 + 2 * SEC + SEC^2 * dT^2$$

With:

SEC Linear material expansion coefficient of the tank shell.

REFTEMP_{SEC} Reference temperature for the tank shell

Note:

The expansion is calculated as a square expansion and not as a cubical expansion. The expansion in the vertical dimension is not relevant, because the actual level is measured and corrected for stilling well expansion.

$F_{\text{therm,vap}}$ is calculated from TAVVAPL

$F_{\text{therm,product}}$ is calculated from TAVPRODL

$F_{\text{therm,water}}$ is calculated from TAVWATERL

7.5.3 Volume correction for floating roofs

The weight of a floating roof causes a level offset in the level in the stilling well. The effect is that there is less product in the tank than measured by the level.

According to Archimedes law the weight of the replace liquid compared to the level in the stilling well is the same as the weight of the roof.

This results in the following correction calculation:

$$RC = \frac{WROOF}{ACTDENS}$$

And

$$RC = REF DENS * VCF$$

With:

WROOF	Roof weight
ACTDENS	Actual density
REFDENS	Density at Reference conditions.
VCF	Volume Correction Factor

The roof correction (RC) will be proportionally less when the level has a value between the support height of the roof and the takeoff height in the stilling well. The roof correction becomes '0' when the level drops below the support height. This is calculated as:

IF $H_{\text{total}} < H_{\text{takeoff}}$ THEN // measured against atmospheric pressure

$$RC = RC * \frac{H_{\text{total}} - H_{\text{support}}}{H_{\text{takeoff}} - H_{\text{support}}}$$

With:

H_{total}	Measured level in the stilling well
H_{takeoff}	Level in the stilling well when the roof lift off from it's support
H_{support}	The height of the supports in the tank

Note:

The roof will not rest on it's support under normal operation conditions.

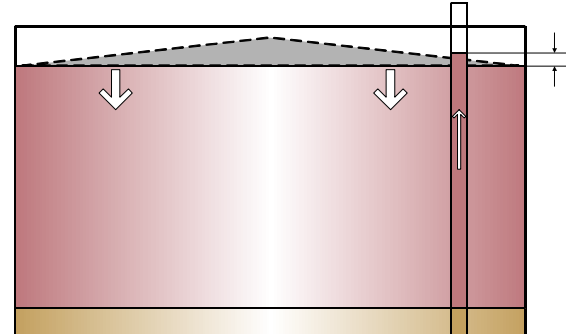

7.5.4 Bulging correction

A tank can deform due to pressure on the inside of the shell caused by the weight of the stored product. The deformation has an expanding effect on the shell circumference and a lowering effect on the roof.

The level reading can have an error when the level instrument is mounted directly on the roof and not on a stilling well. The measured level is higher than the real level in the tank.

The expansion of the shell will result in more liquid being stored at the same level.

The two effects create errors in opposite directions and they both are influenced by the level, the density and the construction of the tank. The total effect is hard to predict or calculate.

A simplified correction can be made by using a bulging factor (TB) for the tank deformation. This factor will be based on experience.

A bulging factor does not apply when the strapping table is determined by filling the tank with a liquid with the same density as in normal use.

7.5.5 Observed Volume

Finally the observed volumes are calculated with all correction in it.

Vapour Room Volume:

$$\begin{aligned} \text{Floating roof tank:} & \quad VRV = 0 \\ \text{Other tanks:} & \quad VRV = V_{vapour} * F_{therm,water} \end{aligned}$$

With

$F_{therm,vap}$ Shell expansion correction vapour room
 V_{vapour} Vapour volume calculated from strapping table

Product volume:

$$\begin{aligned} \text{Floating roof tank:} & \quad V_{product,RC} = V_{product} * F_{therm,product} - RC \\ \text{Other tanks:} & \quad V_{product,RC} = V_{product} * F_{therm,product} \end{aligned}$$

And

$$GOV = V_{product,RC} * (1 + TB)$$

With

$F_{therm,product}$ Shell expansion correction
 $V_{product}$ Product volume calculated from strapping table

Sediment and Water volume:

$$FWV = V_{water} * F_{therm,water}$$

With

FWV

Free Water Volume:

 $F_{therm,product}$

Shell expansion correction

 V_{water}

Water volume calculated from strapping table

Other volumes:

Total Observed Volume (Sediment, Water and product):

$$TOV = GOV * FWV$$

Available Room, or Ullage volume:

$$AR = MAXC - TOV$$

With

MAXC

Maximum capacity of the tank; the part that can be filled safely

7.6 Actual Density

7.6.1 From level and pressure measurement

The actual density of the liquid can be calculated from pressure and level readings by the following formula:

$$ACTDENS = \frac{P1 - P3}{g * (H_{total} - H_{P1})} + D_a$$

With:

g gravity

 H_{total} Measured Level [m] H_{P1} Height of Pressure sensor P1 in use [m] D_a Density of air [kg/m³]

P1 Product pressure in kPa

P3 Vapour pressure in kPa

Note:

The variations in vapour pressure will be small and can be measured in an accurate way by one pressure transmitter (P3).

The pressure at H_{P1} will vary due to the level and density of the liquid. The TTM provides in using two pressure sensors with different ranges to maintain an accurate measurement for a wide range in level.

The reference density can be calculated from the actual density by an iterative VCF calculation according to API D2540. Alternatively the reference density is an external value provided via Modbus.

Note:

The API calculation applies for standard condition of 15 degrees Celsius and 1.01325 bar absolute pressure. Reference conditions for a particular application can differ from the standard conditions. The TTM100 can calculate VCF, GSV and REF DENS for user defined reference conditions.

7.6.2 From level and pressure measurement

The previously described method does not apply when there is no accurate pressure measurement available. Either actual or reference density must be known in order to calculate the other.

In most cases the reference density is an external value provided via Modbus.

The actual density is calculated with the volume correction factor:

$$ACTDENS = REF DENS * VCF$$

The volume correction factor can be calculated according to API D2540 standards.

Note:

The API calculation applies for standard condition of 15 degrees Celsius and 1.01325 bar absolute pressure. Reference conditions for a particular application can differ from the standard conditions. The TTM100 can calculate VCF, GSV and REF DENS for user defined reference conditions.

7.7 Standard Density

7.7.1 API D2540

The volume correction factor to calculate from observed volume to standard volume consists of a correction for temperature and a correction for pressure:

$$VCF = C_{tl} * C_{pl}$$

The correction for temperature to the 15°C reference base:

$$C_{tl} = EXP[-\alpha T * (TEMP - 15) * (1 + 0.8 * \alpha T * (TEMP - 15))]$$

Where:

- C_{ti} Temperature correction factor
- αT Thermal expansion coefficient

The calculation of αT depends on the type of product. API classified different product groups with different K factors to calculate αT .

$$\alpha T = \frac{K_0}{\rho_{15}^2} + \frac{K_1}{\rho_{15}} + K_2$$

Where:

- ρ_{15} Density at reference 15 °C
- K_0, K_1, K_2 Constants, depending on the type of the product

The API table for the 15°C reference base is:

Type of product	Low limit ρ_{15} [kg/m ³]	High limit ρ_{15} [kg/m ³]	K0	K1	K2
Crude	610.5	1075.0	613.9723	0	0
Gasoline	653.0	770.0	346.4228	0.4388	0
Trans.area	770.5	787.5	2680.3206	0	-0.00336312
Jet group	788.0	838.5	594.5418	0	0
Fuel oil	839.0	1075.0	186.9696	0.4862	0
Free fill in	500.0	2000.0	0	0	0

The correction for pressure is:

$$C_{pl} = \frac{1}{1 - F * P * 10^{-4}}$$

Where:

- P Pressure in bar(g)
- F Compressibility factor

Compressibility F is calculated as follows:

$$F = EXP[TERM1 + TERM2 + TERM3 + TERM4] \quad \text{rounded to the nearest 0.0001}$$

And

$$TERM1 = -1.62080$$

$$TERM 2 = 0.00021592 * TEMP \quad \text{rounded to the nearest 0.00001}$$

$$TERM 3 = \frac{0.87096}{\rho_{15}^2 * 10^{-6}} \quad \text{rounded to the nearest 0.00001}$$

$$TERM 4 = \frac{0.0042092 * TEMP}{\rho_{15}^2 * 10^{-6}} \quad \text{rounded to the nearest 0.00001}$$

Where:

TEMP	Temperature in °C rounded to the nearest 0.25 ° C
ρ_{15}	Density at reference conditions rounded to the nearest 2 kg/m3
$(\rho_{15}^2 * 10^{-6})$	Rounded to the nearest 0.00001 (g/cm3) ²

7.7.2 Standard Volume and Mass

The volume at reference condition is:

$$GSV = GOV * VCF$$

With Density Mass is calculated:

$$M = GOV * ACTDENS = GSV * REF DENS$$

8 Alarms

8.1 Instrument alarms

Measured values alarms and status bits coming from BM100 and BM70 instruments are being transferred via Modbus by data transfer blocks. These Modbus blocks are one to one translated from the communication protocol with the connected instruments.

The alarms in these blocks cannot be masked by the TTM100. They are simply available on the Modbus and the TTM100 acts as a transparent unit between the supervisory system and the level instruments.

Some of the alarms are used to determine the reliability of the level measurement, see 7.3.1

The transferred alarm bits coming from the instrument can be used to provide detailed information to an engineer to solve level measurement problems.

BM70

Alarms transferred from a BM70 are:

Alarm	Bit	Meaning
Hardware error flags HWBM70	0	CPU error (NN)
	1	EPROM error (checksum)
	2	RAM error (write/read check)
	3	Interrupt error (NN)
	4	Counter/timer error (NN)
General error flags GEBM70	6	EEPROM error
	13	current output not calibrated
	0	No signal
	1	No peak
Warnings WABM70	2	Microwave error
	8	Current output error (Status)
	9	Switch output error (Status)
	14	Hardware error (general flag)
	15	Fatal Error (general flag)
Microwave flags MFBM70	0	Signal weak
	1	Signal strong
	3	Spectrum poor
	4	Sweep too small
	5	Empty Tank spectrum wrong
	7	Value outdated
	0	Error: Integrator characteristic not rising
	1	Error: VCO range
	2	Error: sweep not reached
	3	Error: voltage increase too high
	10	Warning: voltage increase

BM100

Alarms transferred from a BM100 are:

Alarm	Bit	Meaning
Hardware errors HWBM100	0	ADC Reference Error
	1	ROM Error
	2	RAM Error
	3	EEPROM Factory Error
	4	EEPROM User Error
	5	DAC Error
	6	Strap table Error
Signal errors SEBM100	0	Microwave Error
	1	No End Of Scan Pulse Error
	2	No Reference Pulse Error
	3	No Level Pulse Error
	4	No Interface Pulse Error
	5	Dead Zone Error
Markers (Warnings) WABM100	0	No Reference pulse
	1	No Level pulse
	2	Level frozen
	3	No Interface pulse
	4	Interface frozen
	5	Communication Error

8.2 Input errors

8.2.1 Pt100 errors

The TTM100 detects broken Pt100 series, a Pt100 is assumed to be OK when the measured temperature is within sensor break limits

Pt100 input value lower than the sensor break low limit (`sbr_pt_min`) are caused by a low resistance and are therefore marked as a short circuit errors. Pt100 input value higher than the sensor break high limit (`sbr_pt_max`) are caused by a high resistance and are therefore marked as a open circuit errors

The error bits are stored in variable `Topen` and `Tshort`

Bit 0 is for Pt100 no. 1, bit1 for Pt100 no. 2 and so on.

8.2.2 Analogue input errors

The TTM100 detects analogue inputs errors. An analogue input is assumed to be OK when the measured temperature is within sensor break limits

An open circuit error is raised when the input current is lower than the sensor break low limit (`br_ma_min`). A short circuit error is raised when the input current is higher than the sensor break high limit (`br_ma_max`).

The error bits are stored in variable `Ali,error`

Bit 0 for open circuit analogue input no. 1, bit1 for short circuit analogue input no. 1, bit 2 for open circuit analogue input no. 2, bit3 for short circuit analogue input no. 2 and so on.

8.3 Initialisation errors

The 'init_err' variable indicates the initialization status of the TTM100.

bit0	CRC-error reading first copy of calibration table from EEPROM
bit1	CRC-error reading second copy of calibration table
If bit 0 and 1 set	TTM loaded default calibration value.
bit2	CRC-error reading first copy of parameter table from EEPROM
bit3	CRC-error reading second copy of parameter table
If bit 2 and 3 set	TTM loaded default parameter table
bit4	tank parameters table bad, default loaded
bit5	alarm parameters set bad, default loaded
bit6	configuration parameters bad, default loaded
bit7	display access error, this bit is set if display not connected or damaged.
bit8	primary level controller access error
bit9	secondary level controller access error
bits 7 to 9 set	when the error occurs, the other bits are set during start-up and updated when parameter blocks are written to the instrument
bit 10	HART chan#1 communication failed
bit 11	HART chan#2 communication failed
bit12	strapping table bad, default loaded
bit13	override table bad, default loaded
bit14	sensor ID bad

8.4 Calculation errors

8.4.1 Level calculation errors

The 'ALCALCLEVEL' variable is used to store level calculation errors

bit0	not any level data available, calculation aborted
bit1	not any interface data available, interface level assumed 0.
bit2	interface level higher than product level, assumed: interface level =product level
bit4	primary level source fault
bit5	secondary level source fault
bit6	primary interface level measurement fault.
bit7	secondary interface level measurement fault.

Bits 4 to 7 are set when the instrument errors indicate that the instrument reading is unreliable.

8.4.2 Temperature calculation errors

The 'ALCALCTEMP' variable is used to store temperature calculation errors

bit0	no temperature data for vapour room, reference temp assumed.
bit1	no temperature data for product, reference temperature assumed
bit2	no temperature data for water, reference temperature assumed.
bit4	no Pt100 measurements, occurs when all inputs are marked as not used or produce errors
bit5	no Pt100 sensor in the vapour room, assume: vapour temp=product or interface temperature.
bit6	no Pt100 sensor in product room, assume: product temperature=interface temperature or vapour temperature.
bit7	no Pt100 sensor in water room, assume: temperature water = temperature product.

8.4.3 Pressure calculation errors

The 'ALCALCP' variable is used to store pressure calculation errors.

bit0	P1 pressure bad or missing
bit1	P2 pressure bad or missing
bit2	P3 pressure bad or missing
bit3	P1 < P3, empty tank, no density calculation
bit4	pressure switch-over parameters mismatch PSWHIGH < PSWLOW
bit8	P1A pressure bad or missing
bit9	P1B pressure bad or missing
bit10	P1A in use and P1A pressure < PSWLOW, reduced accuracy (compared to P1B)
bit11	P1B in used and P1B > PSWHIGH, unreliable measurement

8.4.4 Strapping table calculation errors

The 'ALSTRAP' variable is used to store strapping table errors.

The strapping table is used to calculate a volume by linear interpolation. The points in the strapping table must be loaded in the instrument in ascending order, so possible errors are:

bit0	decreasing height segment found
bit1	decreasing volume segment found

8.4.5 Floating roof calculation errors

The 'ALFRC' variable is used to store floating roof correction calculation errors.

bit0	Takeoff height <= Support height
bit1	Reference density = 0
bit2	VCF = 0

8.4.6 Density calculation errors

The 'ALDENS' variable is used to store density calculation errors.

bit0	HTG ACTDENS calculation error (when $g = 0$ or $H_{total} = H_{P1}$)
bit1	DEN ₁₅ calculation error (loop doesn't converge)
bit8	no actual density measurements data or calc error
bit9	no reference density measurements data or calc error

8.4.7 API D2540 calculation errors

The 'ALAPI2540' variable is used to store API calculation errors.

bit0	C _{tl} alpha calculation error ($\rho_{15} = 0$)
bit1	C _{tl} K-factors error ($K_0 = K_1 = K_2 = 0$)
bit2	C _{pl} F calculation error ($\rho_{15} = 0$)
bit3	C _{pl} calculation error ($F * P * 10^{-4} = 1$)
bit4	Density Product type mismatch

8.5 Limit Alarms

Limit alarm are raised when process values are out of the normal operation range. The limits are given by parameters.

The alarm values for process alarms are defined as:

bit0	– LoLo alarm
bit1	– Lo alarm
bit2	– Hi alarm
bit3	– HiHi alarm
bit4	– Parameter conflict

The alarm check cannot be performed when the alarm limit parameters are configured wrong. In this case bit4 is set to notify the user. A parameter conflict occurs when:

The hysteresis functionality is explained in the next diagram:

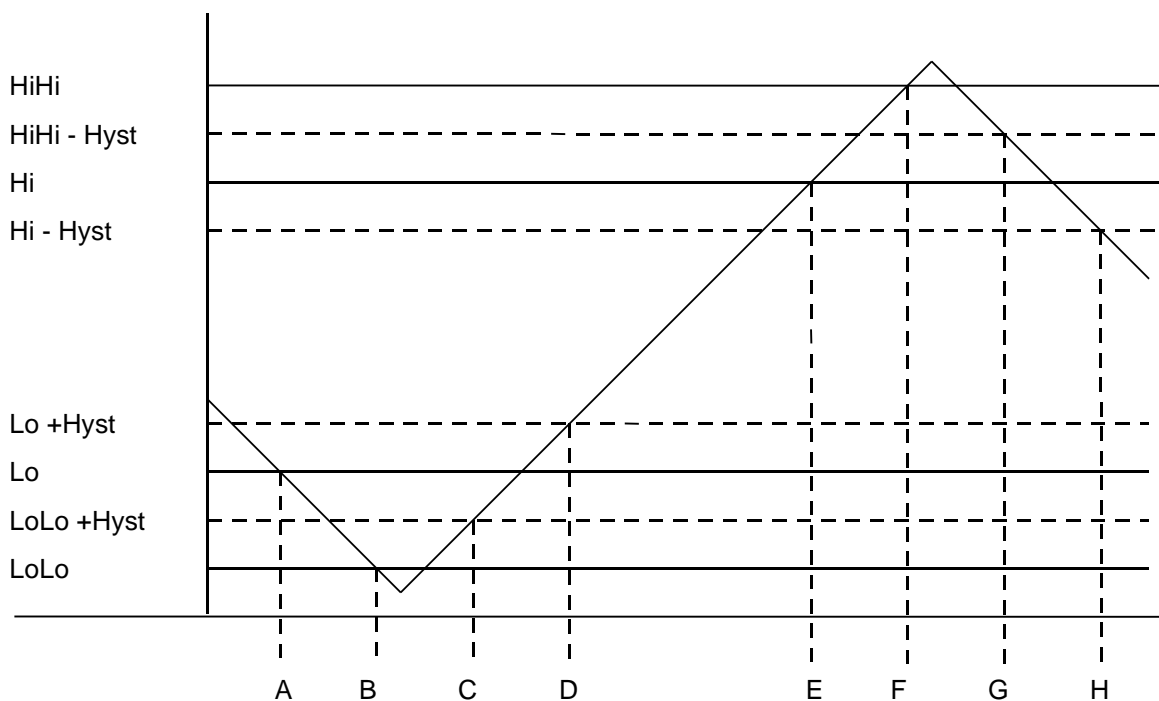

- A: Value decreases Lo alarm limit -> Lo alarm
 B: Value decreases LoLo alarm limit -> LoLo alarm
 C: Value increases LoLo alarm limit + Hysteresis -> Lo alarm
 D: Value increases Lo alarm limit + Hysteresis -> Normal (No alarm)
 E: Value increases Hi alarm limit -> Hi alarm
 F: Value increases HiHi alarm limit -> HiHi alarm
 G: Value decreases HiHi alarm limit – Hysteresis -> Hi alarm
 H: Value decreases Hi alarm limit – Hysteresis -> Normal (No alarm)

The next process values are checked for process alarms:

Name	Description
ALLVL	Limit alarm on level
ALINT	Limit alarm on interface
ALTAVVAP	Limit alarm on TAVVAP
ALTAVPROD	Limit alarm on TAVPROD
ALTAVWATER	Limit alarm on TAVWATER
ALPRESS	Limit alarm on PAVPROD

9 Miscellaneous Functionality

9.1 Input filtering

Filtering the inputs reduces noise and increase stability.

Every second a new filtered value is calculated by a running average calculation:

$$Val_{n+1} = \frac{Val_n * (FF - 1) + Input}{FF}$$

With:

Val Filtered value

FF Filter factor

Input Latest input reading

Note:

The filter is disabled when FF is set to 0.

9.2 Alarm Masking and Relay Outputs

The TTM100 is capable of generating a variety of alarms. Not all alarms are important to users and not all alarms are applicable for the application used. Alarms can be masked to prevent users being overloaded with unimportant or misleading alarms.

Alarms are routed to two relay outputs and to the Modbus for use in a supervisory system. The alarms are individually represented by bits on the Modbus link. The relay outputs are activated by an OF function of all alarms.

Three sets of masks are implemented. One set is used to mask alarms on the Modbus alarm block and both relays has a set of masks. Different alarm gates can be created for the relays by masking different alarms.

9.3 Internal Temperature Control

The internal temperature can be regulated for extreme cold ambient temperatures.

It serves 2 purposes:

- The local display will fail under these conditions without a heater inside.
- Electronic circuit's last longer when very low temperature are prevented.

9.4 Level Instrument Configuration

The user configuration of Krohne level instruments can be done remotely via the TTM100 Modbus interface. The TTM100 translates the Modbus messages to Krohne protocol and vice versa.

Note:

Factory settings can only be changed by using dedicated configuration tools.

9.5 Diagnostics

A set of data is available via Modbus to investigate the instrument behaviour in detail. It shows intermediate results of calculations and unmasked alarms.

Name	Description
Sort_H _{T1}	Sorted T1 element height
Sort_H _{T2}	Sorted T2 element height
Sort_H _{T3}	Sorted T3 element height
Sort_H _{T4}	Sorted T4 element height
Sort_H _{T5}	Sorted T5 element height
Sort_H _{T6}	Sorted T6 element height
Sort_H _{T7}	Sorted T7 element height
Sort_H _{T8}	Sorted T8 element height
Sort_H _{T9}	Sorted T9 element height
Sort_H _{T10}	Sorted T10 element height
Sort_H _{T11}	Sorted T11 element height
Sort_H _{T12}	Sorted T12 element height
Sort_H _{T13}	Sorted T13 element height
Sort_H _{T14}	Sorted T14 element height
Sort_H _{T15}	Sorted T15 element height
Sort_H _{T16}	Sorted T16 element height
Temp _{T1}	Temp of T1 Sorted Pt100
Temp _{T2}	Temp of T1 Sorted Pt100
Temp _{T3}	Temp of T1 Sorted Pt100
Temp _{T4}	Temp of T1 Sorted Pt100
Temp _{T5}	Temp of T1 Sorted Pt100
Temp _{T6}	Temp of T1 Sorted Pt100
Temp _{T7}	Temp of T1 Sorted Pt100
Temp _{T8}	Temp of T1 Sorted Pt100
Temp _{T9}	Temp of T1 Sorted Pt100
Temp _{T10}	Temp of T1 Sorted Pt100
Temp _{T11}	Temp of T1 Sorted Pt100
Temp _{T12}	Temp of T1 Sorted Pt100
Temp _{T13}	Temp of T1 Sorted Pt100
Temp _{T14}	Temp of T1 Sorted Pt100
Temp _{T15}	Temp of T1 Sorted Pt100
Temp _{T16}	Temp of T1 Sorted Pt100
pt_used	count of active used Pt elements
tav_vap_l	avr. vapour temp lin. weighted
tav_prod_l	avr. prod temp lin. weighted
tav_interf_l	avr. interf temp lin. weighted
tav_vap	avr. vapour temp vol. weighted
tav_prod	avr. prod temp vol. weighted
tav_interf	avr. interf temp vol. weighted
CT _{vapour}	Stilling well correction factor vapour part
CT _{liquid}	Stilling well correction factor liquid part
CT _{water}	Stilling well correction factor water part
dH _{STW1}	Stilling well correction primary level
dH _{STW2}	Stilling well correction secondary level
dH _{STWT}	Stilling well correction temp probe
CorrLevel1	Level corrected for primary level stilling well expansion
CorrInterface1	Interface corrected for primary level stilling well expansion
CorrLevel2	Level corrected for secondary level stilling well expansion
CorrInterface2	Interface corrected for secondary level stilling well expansion

9 Miscellaneous Functionality

Name	Description
CorrSTWTemp	Corrected stilling well height of temp probe.
V _{total}	Volume of water plus product derived from strapping table
V _{product}	Volume of product derived from strapping table
V _{vapour}	Volume of vapour room derived from strapping table
V _{water}	Volume of water derived from strapping table
F _{therm,product}	Shell expansion factor product section
F _{therm,vap}	Shell expansion factor vapour section
F _{therm,water}	Shell expansion factor water section
VCF _{ACT15}	VCF between ACTDENS and DENS ₁₅
C _{pl,ACT15}	Correction for pressure between ACTDENS and DENS ₁₅
C _{tl,ACT15}	Correction for temperature between ACTDENS and DENS ₁₅
VCF _{REF15}	VCF between REF DENS and DENS ₁₅
C _{pl,REF15}	Correction for pressure between REF DENS and DENS ₁₅
C _{tl,REF15}	Correction for temperature between REF DENS and DENS ₁₅
VCF	Correction for temperature between REF DENS and ACTDENS
K ₀	Used K factor
K ₁	Used K factor
K ₂	Used K factor
dens_p	act density calculated from pressure
last_bmerr	last error code for TTM-BM70/100 communication bit0 - message to long (buffer ovr. bit1 - checksum bad bit2 - bad device ID bit3 - bad device address bit4 - bad device version bit5 - incorrect message length bit6 - unknown function
cur_ma1	Actual current at an. input 1
cur_ma2	Actual current at an. input 2
cur_ma3	Actual current at an. input 3
cur_ma4	Actual current at an. input 4
cur_ma5	Actual current at an. input 5
cur_ma6	Actual current at an. input 6
cur_ma7	Actual current at an. input 7
cur_ma8	Actual current at an. input 8
NM_T _{open}	non masked alarm T _{open}
NM_T _{short}	non masked alarm T _{short}
NM_Al _{error}	non masked alarm Al _{error}
NM_ALCALCLEVEL	non masked alarm ALCALCLEVEL
NM_ALCALCTEMP	non masked alarm ALCALCTEMP
NM_init_err	non masked alarm init_err
NM_ALCALCP	non masked alarm ALCALCP
NM_ALSTRAP	non masked alarm ALSTRAP
NM_ALFRC	non masked alarm ALFRC
NM_ALDENS	non masked alarm ALDENS
NM_ALAPI2540	non masked alarm ALAPI2540
NM_ALLVL	non masked alarm ALLVL
NM_ALINT	non masked alarm ALINT
NM_ALTAVVAP	non masked alarm ALTAVVAP
NM_ALTAVPROD	non masked alarm ALTAVPROD
NM_ALTAVWATER	non masked alarm ALTAVWATER
NM_ALPRESS	non masked alarm ALPRES

10 Configuration

10.1 General

All configurations are done via the Modbus interface. A special tool, TTM100 Monitor, is provided to configure the instrument.

The next paragraphs describe the different settings to configure the instrument.

10.2 System Parameters

10.2.1 Input filtering

Filtering the inputs can reduce noise and increase stability. Every second a new filtered value is calculated by a running average calculation:

Parameters are:

filter_pt	Filter factor for Pt100 inputs. [s]
filter_ma	Filter factor for mA inputs. [s]

10.2.2 Communication settings

Parameters for the Modbus port comport 1 are:

com_addr	Modbus interface address
com_baud	Modbus interface baud rate index:
	0 = 2400 baud
	1 = 4800 baud
	2 = 9600 baud (default)
	3 = 19200 baud

Default address is 1 and the default baudrate is 9600.

Changing the settings with the TTM Monitor forces the user to make the same changes in the TTM Monitor setting to maintain communication.

devi_name TTM100 device name can be used to give the TTM100 a tag name.

The setting for communication with BM70 and BM100 instruments on comm2 are:

bm_stat	bm70/bm100 status
	bit2..bit0 baud rate:
	000 = 2400 baud
	001 = 4800 baud
	010 = 9600 baud
	011 = 19200 baud
	bit9..bit8 - primary level controller
	00 = none
	01 = BM70
	10 = BM100

	bit11..bit10 - secondary level controller
	00 = none
	01 = BM70
	10 = BM100
bm_p_adr	Primary BM70/100 address
bm_s_adr	Secondary BM70/100 address
bm_p_ver	Primary BM70/100 version
bm_s_ver	Secondary BM70/100 version

10.2.3 Internal temperature control

Parameters for the internal temperature controller are:

t_reg_sp	Set point of internal temperature controller
t_reg_p	Proportional factor of internal temperature controller
t_reg_i	Integral time of internal temperature controller
t_reg_cyc	Cycle time of internal temperature controller

10.2.4 Display configuration

A total of 20 display lines can be configured. Because there are physically only 2 lines available the lines are divided in 10 displays with 2 lines and the software switches from one display to the other.

dsp_cycle	display switching cycle. Unit = 0.1s
dsp_count	count of display switching.

I.e. dsp_count =3 means that the display is switched between dsp1,dsp2,dsp3 and back to dsp1. The switching cycle time is determined by dsp_cycle

Each line can be provided with a background text. A variable can be displayed as foreground text.

Variables are configured as indices from a list of available variables to show on the display. The format used to show the variable is also configurable

Parameters with variable indices:

dsp11_var	line 1 of display 1 - variable index (-1 for 'text only' display)
dsp12_var	line 1 of display 2 - variable index
....	
dsp110_var	line 1 of display 10 - variable index
dsp21_var	line 2 of display 1 - variable index
....	
dsp210_var	line 2 of display 10 - variable index

List of indices and variable that can be selected to display.

Index	Variable	Description
-1	None	Only text on the display line
0	pt1_raw	current raw a/d reading of Pt100 #1
1	pt2_raw	current raw a/d reading of Pt100 #2
2	pt3_raw	current raw a/d reading of Pt100 #3
3	pt4_raw	current raw a/d reading of Pt100 #4
4	pt5_raw	current raw a/d reading of Pt100 #5
5	pt6_raw	current raw a/d reading of Pt100 #6
6	pt7_raw	current raw a/d reading of Pt100 #7
7	pt8_raw	current raw a/d reading of Pt100 #8
8	pt9_raw	current raw a/d reading of Pt100 #9
9	pt10_raw	current raw a/d reading of Pt100 #10
10	pt11_raw	current raw a/d reading of Pt100 #11
11	pt12_raw	current raw a/d reading of Pt100 #12
12	pt13_raw	current raw a/d reading of Pt100 #13
13	pt14_raw	current raw a/d reading of Pt100 #14
14	pt15_raw	current raw a/d reading of Pt100 #15
15	pt16_raw	current raw a/d reading of Pt100 #16
16	ma1_raw	current raw a/d reading of mA input #1
17	ma 2_raw	current raw a/d reading of mA input #2
18	ma 3_raw	current raw a/d reading of mA input #3
19	ma 4_raw	current raw a/d reading of mA input #4
20	ma 5_raw	current raw a/d reading of mA input #5
21	ma 6_raw	current raw a/d reading of mA input #6
22	ma 7_raw	current raw a/d reading of mA input #7
23	ma 8_raw	current raw a/d reading of mA input #8
24	T1	TTM100 reading T1
25	T2	TTM100 reading T2
26	T3	TTM100 reading T3
27	T4	TTM100 reading T4
28	T5	TTM100 reading T5
29	T6	TTM100 reading T6
30	T7	TTM100 reading T7
31	T8	TTM100 reading T8
32	T9	TTM100 reading T9
33	T10	TTM100 reading T10
34	T11	TTM100 reading T11
35	T12	TTM100 reading T12
36	T13	TTM100 reading T13
37	T14	TTM100 reading T14
38	T15	TTM100 reading T15
39	T16	TTM100 reading T16
40	AI1	Reading input 1 in eng. Units
41	AI2	Reading input 2 in eng. Units
42	AI3	Reading input 3 in eng. Units
43	AI4	Reading input 4 in eng. Units
44	AI5	Reading input 5 in eng. Units
45	AI6	Reading input 6 in eng. Units
46	AI7	Reading input 7 in eng. Units
47	AI8	Reading input 8 in eng. Units
48	P1A	Wide range P1 reading
49	P1B	Small range P1 reading
50	P1	P1 reading
51	P2	Future P2 reading
52	P3	Vapour pressure

Index	Variable	Description
53	Level1	Primary level reading
54	Level2	Secondary level reading
55	Interface1	Primary Interface reading
56	Interface2	Secondary Interface reading
57	Level	Used level reading
58	Interface	Used Interface reading
59	CorrLevel	Level used and corrected for stilling well expansion
60	CorrInterface	Interface used and corrected for stilling well expansion
61	LevelUsed	Selected instrument : bit0 - product level: 0 = primary, 1 = secondary. bit1 - interface level: 0= primary, 1 = secondary
62	TAVPRODL	Lin Weighted Average Temperature of product
63	TAVVAPL	Lin Weighted Average Temperature of vapour room
64	TAVWATERL	Lin Weighted Average Temperature of water layer
65	TAVPROD	Vol Weighted Average Temperature of product
66	TAVVAP	Vol Weighted Average Temperature of vapour room
67	TAVWATER	Vol Weighted Average Temperature of water layer
68	PressureUsed	Selected pressure transmitter 1 = P1A, 2 = P1B
69	H _{P1}	Height of selected pressure transmitter
70	PAVPROD	Average product pressure
71	RC	Roof correction
72	TOV	Total Observed Volume (product and water)
73	GOV	Gross Observed Volume
74	AR	Available room or Ullage volume
75	FWV	Free Water Volume
76	VRV	Vapour Room Volume
77	VCF	Volume Correction Factor between REFDENS and ACTDENS
78	ACTDENS	Actual Density
79	REFDENS	Density at reference conditions (When calculated)
80	DENS ₁₅	Density at 15 °C
81	GSV	Gross Standard Volume
82	MASS	Total Mass of product
83	PROD_TYPE	Product type
84	TB	Bulging correction
85	Productname	Name of stored product
86	MAINT	Tank in maintenance or operation
87	DEV_TEMP	Internal TTM Temperature
88	HART_1_PV	HART 1 Process variable
89	HART_2_PV	HART 2 Process variable
90	HART_3_PV	HART 3 Process variable
91	HART_4_PV	HART 4 Process variable

Parameters with formats:

dsp11_for line 1 of display 1 - display format:
 bits 3..0 - variable display position. right justified.
 bits 6..4 - precision. applicable only to floating point variables (single,double)

....

dsp210_for line 2 of display 10 - display format:

Parameters with background text:

dsp11_txt line1 of display 1 - background text

....
 dsp210_txt line2 of display 10 - background text

The display contrast is configurable with parameter dsp_contr.

10.2.5 Communication line termination resistor

There are 3 switches build in the TTM100 to switch on termination resistors on the communication line.

Parameter:

rel_stat relay status
 bit0 = termination for com1
 bit1 = termination for com2
 bit2 = termination for com3

RS485 communication line must be terminated at the end and at the beginning of the line. The termination must be switched on in the TTM100 at the end of the communication line. Other TTM100's on the same communication line should have their termination switched off.

10.2.6 Sensor break limit

The TTM100 detects broken Pt100 series, a Pt100 is assumed to be OK when the measured temperature is within following limits:

sbr_pt_min Pt100 sensor break limit low in degrees Celsius
 sbr_pt_max Pt100 sensor break limit high in degrees Celsius

Note:

Broken sensors are left out of the average temperature calculations.

Similar limits are applicable to analogue inputs:

br_ma_min Analogue input sensor break limit low in mA
 br_ma_max Analogue input sensor break limit high in mA

An open circuit is detected when the input current is less than the minimum limit, a short circuit is detected when the input current exceeds the maximum limit.

10.2.7 Analogue input scaling

The next parameters are used for this scaling from mA values to engineering units.

scph0_ma1 mA value at 0% of the scale of input 1
 ...
 scph0_ma8 mA value at 0% of the scale of input 8

scph1_ma1	mA value at 100% of the scale of input 1
...	
scph1_ma8	mA value at 100% of the scale of input 8
sceu0_ma1	value in engineering units at 0% of the scale of input 1
...	
sceu0_ma8	value in engineering units at 0% of the scale of input 8
sceu1_ma1	value in engineering units at 100% of the scale of input 1
...	
sceu1_ma8	value in engineering units at 100% of the scale of input 8

10.3 Tank parameters

10.3.1 Tank dimensions

H_{tank}	Tank Height [mm]
H_{stwell1}	Height of the primary level stilling well [mm]
H_{stwell2}	Height of the secondary level stilling well [mm]
H_{stwellT}	Height of the temp probe stilling well [mm]
H_{support}	Height of roof support in floating roof tanks [mm]
H_{takeoff}	Height of level in stilling well when roof is lifted from its support [mm]
H_{P1A}	Height of pressure transmitter P1A [mm]
H_{P1B}	Height of pressure transmitter P1B [mm]
WROOF	Roof Weight [kg]
V_{tank}	Total Tank volume [m^3]
MAXC	Maximum capacity of the storage tank [m^3]

Note that all heights are related to a reference height near the bottom of the tank.

10.3.2 Other tank related parameters

REFTEMP	Reference temperature [$^{\circ}\text{C}$]
REFTEMP _{SEC}	Reference temperature for shell expansion calculation [$^{\circ}\text{C}$]
REFTEMP _{STWEC}	Reference temperature for stilling well expansion calculation [$^{\circ}\text{C}$]
STWEC	Stilling well expansion coefficient [$^{\circ}\text{C}^{-1}$]
SEC	Shell expansion coefficient [$^{\circ}\text{C}^{-1}$]
D_a	Density of air [kg/m^3]
TB	Bulging correction
PSWHIGH	Pressure P1B high switchover [%]
PSWLOW	Pressure P1B low switchover [%]
g	Gravity acceleration
K_0	K – factor for free fill in
K_1	K – factor for free fill in
K_2	K – factor for free fill in

DBTC _{UPPER}	Upper limit for dead band in average temperature calculation
DBTC _{LOWER}	Lower limit for dead band in average temperature calculation

10.4 Alarm Limits

Alarm limits are in to determine 4 alarm level for the next process values:

- Level (in use)
- Interface (in use)
- Volume weighted average vapour temperature (TAVVAP)
- Volume weighted average product temperature (TAVPROD)
- Volume weighted average water temperature (TAVWATER)
- Average pressure

A hysteresis value is provided to prevent unstable alarms

Parameters:

LoLoLVL	LoLoINT	LoLoTAVVAP	LoLoTAVPROD	LoLoTAVWATER	LoLoPRESS
LoLVL	LoINT	LoTAVVAP	LoTAVPROD	LoTAVWATER	LoPRESS
HiLVL	HiINT	HiTAVVAP	HiTAVPROD	HiTAVWATER	HiPRESS
HiHiLVL	HiHiINT	HiHiTAVVAP	HiHiTAVPROD	HiHiTAVWATER	HiHiPRESS
HystLVL	HystINT	HystTAVVAP	HystTAVPROD	HystTAVWATER	HystPRESS

10.5 System Configuration

10.5.1 Probe dimensions

The heights of the Pt100 elements are calculated from the stilling well height and the distance of each element to the flange.

Parameters:

L _{T1}	Distance flange to Pt100 no. 1	[mm]
....		
L _{T16}	Distance flange to Pt100 no. 16	[mm]

A status word determines which Pt100 inputs are used or not.

Parameter

T _{i,on/off}	On/Off status of Pt100
	Bit 0 : 0 = Pt100 no. 1 is Off, 1 = Pt100 no. 1 is On

	Bit 15 : 0 = Pt100 no. 16 is Off, 1 = Pt100 no. 16 is On

10.5.2 Input assignment

Process values can be assigned to a certain input to meet different setup needs in field instrumentation.

A table with numbers determines the input assignments:

- 0 None / Not used
- 1 - 8 Analogue input 1 - 8
- 9 Analogue input 1 HART protocol
- 10 Analogue input 2 HART protocol
- 11 Level instrument
- 12 From pressure
- 13 Temperature probe
- 14 Modbus override (from supervisory system)

Assignment parameters are:

- ASP1A Input assignment Pressure P1A
- ASP1B Input assignment Pressure P1B
- ASP2 Input assignment Pressure P2
- ASP3 Input assignment Pressure P3
- ASTAVV Input assignment Average vapour temperature
- ASTAVP Input assignment Average product temperature
- ASTAVW Input assignment Average water temperature
- ASLVL1 Input assignment Primary level
- ASINT1 Input assignment Primary interface
- ASLVL2 Input assignment Secondary level
- ASINT2 Input assignment Secondary interface
- ASACTD Input assignment Actual density
- ASREFD Input assignment Reference density

A matrix shows the valid assignments for the TTM100:

Input value assignment	Analog input 1-8	Hart input 9-10	Level instrument 11	From pressure instrument 12	Temperature Probe 13	Modbus override 14
ASP1A	X	X				X
ASP1B	X	X				X
ASP2	X	X				X
ASP3	X	X				X
ASTAVV	X				X	X
ASTAVP	X				X	X
ASTAVW	X				X	X
ASLVL1	X	X	X			X
ASINT1	X	X	X			X
ASLVL2	X	X	X			X
ASINT2	X	X	X			X
ASACTD	X			X		X
ASREFD						X

Note:

ASACTD being set to 'From pressure' (12) implies that the Hybrid calculation is being performed. The actual density is calculated from pressure values P1 and P3 and the distance between the height of the P1 transmitter in use and the corrected level measurement.

10.5.3 HART devices

HART instruments are described by the Manufacturer Code and Device Code.

Known instruments are:

Manufacturer	Type	Measured value	Manufacturer Code	Device Code
Krohne	Optiwave	Level	0x45	
Krohne	Optiflex	Level	0x45	
Yokogawa	EJA	Pressure	0x37	0x04
Yokogawa	YTA	Temperature	0x37	0x09

The HART devices are specified by:

hart1_dev	bit0-7:	Manufacturer code	input 1
	bit8-15:	Device code	input 1
hart2_dev	bit0-7:	Manufacturer code	input 2
	bit8-15:	Device code	input 2
hart3_dev	bit0-7:	Manufacturer code	input 3
	bit8-15:	Device code	input 3
hart4_dev	bit0-7:	Manufacturer code	input 4
	bit8-15:	Device code	input 5

The specific Device ID's are set in:

hart1_id	Device ID	input 1
hart2_id	Device ID	input 2
hart3_id	Device ID	input 3
hart4_id	Device ID	input 4

Primary values coming from HART can be scaled by using:

hart1_span	span factor for measured value on input 1
hart2_span	span factor for measured value on input 2
hart3_span	span factor for measured value on input 1
hart4_span	span factor for measured value on input 2

hart1_zero	offset for measured value on input 1
hart2_zero	offset for measured value on input 2
hart3_zero	offset for measured value on input 1
hart4_zero	offset for measured value on input 2

10.5.4 Pressure measurement

Pressure transmitters can measure absolute pressure or differential pressure against atmospheric pressure. As long as the transmitters are all the same kind there is no difference for the actual density calculation. but there is a difference for the average pressure being used in the API calculations.

The next setting tells the TTM100 what kind of transmitters is used:

PressType	0 = differential pressure measurement
	1 = absolute pressure measurement

10.5.5 Tank related calculations configuration

Since the TTM100 is a very flexible instrument some parameters are needed to select the required calculations to perform with the required options.

The type of tank determines if there is a vapour room or not.

Parameters:

Tanktype	Shape of the tank
	0 = Fixed roof
	1 = Floating roof
	2 = Sphere

FRCTYPE	Roof weight correction
	0 = No floating roof correction calculated
	1 = Floating roof correction

Note:

Both Tanktype and FRCTYPE must be set correctly if a floating roof correction is required. The floating roof correction will not be calculated when the Tanktype is not 'Floating roof'.

The next parameters determine other correction to be carried out or not:

STWCtype	Stilling well correction; 0 = No, 1 = Yes
SECTYPE	Tank shell correction; 0 = No, 1 = Yes
BCtype	Bulging correction. ; 0 = No, 1 = Yes

10.5.6 Product related calculations configuration

CalcMethod describes which method is used to calculate VCF

CalcMethod Calculation method for VCF -
 0 = No Density calculation
 1 = API Standard with 15 degrees Celsius as reference

VCFtype describes which options are used for VCF calculation

VCFtype 0 = No correction
 1 = Only temperature correction
 2 = Temperature and pressure correction

Refcond parameter is used to tell the TTM100 that the reference conditions are the same as standard conditions (15 degrees Celsius and 1.01325 bara)

Refcond Standard or no standard reference conditions ; 0 = No, 1 = Yes

Product type describes the product group to be used for the API calculations. K_0 , K_1 and K_2 must be configured when Free fill in option is chosen.

Product type Type of product in the tank
 0 = No selection
 1 = Crude
 2 = Gasoline
 3 = Trans. area
 4 = Jet group
 5 = Fuel oil
 6 = Free fill in

10.5.7 Alarm masking

All masking parameters start with MSK<number>

The number is related to the output for which alarms are masked

Example:

MSK1INST Instrument alarms masked for Relay 1
 MSK2INST Instrument alarms masked for Relay 2
 MSK3INST Instrument alarms masked for Modbus (Supervisory)

The following list describes the alarm masking parameters

The masking parameters perform a "bitwise AND" function on the related alarm status.

An "OF" function of all alarms, filtered by 'MSK1xxx', controls relays output.1.

An "OF" function of all alarms, filtered by 'MSK2xxx', controls relays output.2.

The alarms, filtered by MSK3xxx, are communicated via the Modbus alarm block.

The unmasked alarms are available on Modbus block diagnostics.

The next table shows the masking parameters and the related alarm variable

Mask relays 1	Mask relays 2	Mask on Modbus	Alarm variable
MSK1PTOPEN	MSK2PTOPEN	MSK3PTOPEN	T _{open}
MSK1PTSHORT	MSK2PTSHORT	MSK3PTSHORT	T _{short}
MSK1AIER	MSK2AIER	MSK3AIER	Al _{error}
MSK1CLVL	MSK2CLVL	MSK3CLVL	ALCALCLEVEL
MSK1CTMP	MSK2CTMP	MSK3CTMP	ALCALCTEMP
MSK1INITERR	MSK2INITERR	MSK3INITERR	init_err
MSK1CPRS	MSK2CPRS	MSK3CPRS	ALCALCP
MSK1STRP	MSK2STRP	MSK3STRP	ALSTRAP
MSK1FRC	MSK2FRC	MSK3FRC	ALFRC
MSK1CDNS	MSK2CDNS	MSK3CDNS	ALDENS
MSK1CAPI	MSK2CAPI	MSK3CAPI	ALAPI2540
MSK1LVL	MSK2LVL	MSK3LVL	ALLVL
MSK1INT	MSK2INT	MSK3INT	ALINT
MSK1TAVVAP	MSK2TAVVAP	MSK3TAVVAP	ALTAVVAP
MSK1TAVPROD	MSK2TAVPROD	MSK3TAVPROD	ALTAVPROD
MSK1TAVWATER	MSK2TAVWATER	MSK3TAVWATER	ALTAVWATER
MSK1PRES	MSK2PRES	MSK3PRES	ALPRESS

11 Ordering Information

TTM100 B No
 Yes Power Supply 230VAC 115VAC 24VDC
 Heater No Yes
 HART communication No Yes

TTM100 A No Yes

Temp Probe No
 Yes Pt100 Accuracy Class A A 1/10

Probe length _____ mm
 Number of Pt100's _____
 Distance of each Pt100 to the Flange face:
 Pt100 no. 1 _____ mm
 Pt100 no. 2 _____ mm
 Pt100 no. 3 _____ mm
 Pt100 no. 4 _____ mm
 Pt100 no. 5 _____ mm
 Pt100 no. 6 _____ mm
 Pt100 no. 7 _____ mm
 Pt100 no. 8 _____ mm
 Pt100 no. 9 _____ mm
 Pt100 no. 10 _____ mm
 Pt100 no. 11 _____ mm
 Pt100 no. 12 _____ mm
 Pt100 no. 13 _____ mm
 Pt100 no. 14 _____ mm
 Pt100 no. 15 _____ mm
 Pt100 no. 16 _____ mm

Flange size and material _____

Element material _____

Counterweight No
 Yes, standard
 Yes, special size:
 Diameter _____ mm
 Height _____ mm

A Communication

A.1 BM70/BM100 Krohne Protocol

See BM70/BM100 documentation

A.2 Modbus Protocol

A.2.1 General

Some Modbus blocks contain holding registers and others input registers.

Holding registers are used for settings and are read/write.

Modbus functions applicable for holding registers are:

- 3, read holding registers
- 6, write single holding register
- 16, (hexadecimal 10) write multiple holding registers

Input registers are use to read data.

Modbus functions applicable for input registers are:

- 4, read input registers

Blocks with holding registers (modbus functions 3,6,16) are:

- System Variables (start at 0)
- Calibration (start at 1000)
- System Parameters (start at 2000)
- Tank Parameters (start at 3000)
- Alarm Limits (start at 4000)
- Configuration (start at 5000)
- Override Values (start at 6000)
- Strapping tables (start at 10000)

Blocks with input registers (modbus function 4) are

- Raw Data (start at 0)
- Measured Data (start at 1000)
- BM70 Data (start at 2000)
- BM100 Data (start at 3000)
- Calculated Data (start at 4000)
- Diagnostics (start at 5000)
- Alarms (start at 6000)
- HART Diagnostics (start at 7000)

A.2.2 Calibration

Block calibration data

Modbus Address	Name	Type	Description
1001	raw0_pt1	long	raw a/d reading for 1st calibration point of Pt100 sensor #1
1003	raw0_pt2	long	raw a/d reading for 1st calibration point of Pt100 sensor #2
1005	raw0_pt3	long	----- sensor #3
1007	raw0_pt4	long	----- sensor #4
1009	raw0_pt5	long	----- sensor #5
1011	raw0_pt6	long	----- sensor #6
1013	raw0_pt7	long	----- sensor #7
1015	raw0_pt8	long	----- sensor #8
1017	raw0_pt9	long	----- sensor #9
1019	raw0_pt10	long	----- sensor #10
1021	raw0_pt11	long	----- sensor #11
1023	raw0_pt12	long	----- sensor #12
1025	raw0_pt13	long	----- sensor #13
1027	raw0_pt14	long	----- sensor #14
1029	raw0_pt15	long	----- sensor #15
1031	raw0_pt16	long	----- sensor #16
1033	raw1_pt1	long	raw a/d reading for 2nd calibration point of Pt100 sensor #1
1035	raw1_pt2	long	----- sensor #2
1037	raw1_pt3	long	----- sensor #3
1039	raw1_pt4	long	----- sensor #4
1041	raw1_pt5	long	----- sensor #5
1043	raw1_pt6	long	----- sensor #6
1045	raw1_pt7	long	----- sensor #7
1047	raw1_pt8	long	----- sensor #8
1049	raw1_pt9	long	----- sensor #9
1051	raw1_pt10	long	----- sensor #10
1053	raw1_pt11	long	----- sensor #11
1055	raw1_pt12	long	----- sensor #12
1057	raw1_pt13	long	----- sensor #13
1059	raw1_pt14	long	----- sensor #14
1061	raw1_pt15	long	----- sensor #15
1063	raw1_pt16	long	----- sensor #16
1065	ph0_pt1	float	Physical value[°C] corresponding to the 1st calibration point of Pt100 sensor #1
1067	ph0_pt2	float	----- sensor #2
1069	ph0_pt3	float	----- sensor #3
1071	ph0_pt4	float	----- sensor #4
1073	ph0_pt5	float	----- sensor #5
1075	ph0_pt6	float	----- sensor #6
1077	ph0_pt7	float	----- sensor #7
1079	ph0_pt8	float	----- sensor #8
1081	ph0_pt9	float	----- sensor #9
1083	ph0_pt10	float	----- sensor #10
1085	ph0_pt11	float	----- sensor #11
1087	ph0_pt12	float	----- sensor #12
1089	ph0_pt13	float	----- sensor #13
1091	ph0_pt14	float	----- sensor #14
1093	ph0_pt15	float	----- sensor #15
1095	ph0_pt16	float	----- sensor #16

Modbus Address	Name	Type	Description
1097	ph1_pt1	float	Physical value[°C] corresponding to the 2nd calibration point of Pt100 sensor #1
1099	ph1_pt2	float	----- sensor #2
1101	ph1_pt3	float	----- sensor #3
1103	ph1_pt4	float	----- sensor #4
1105	ph1_pt5	float	----- sensor #5
1107	ph1_pt6	float	----- sensor #6
1109	ph1_pt7	float	----- sensor #7
1111	ph1_pt8	float	----- sensor #8
1113	ph1_pt9	float	----- sensor #9
1115	ph1_pt10	float	----- sensor #10
1117	ph1_pt11	float	----- sensor #11
1119	ph1_pt12	float	----- sensor #12
1121	ph1_pt13	float	----- sensor #13
1123	ph1_pt14	float	----- sensor #14
1125	ph1_pt15	float	----- sensor #15
1127	ph1_pt16	float	----- sensor #16
1129	off0_pt1	float	Physical offset[°C] of the 1st calibration point of Pt100 sensor #1
1131	off0_pt2	float	----- sensor #2
1133	off0_pt3	float	----- sensor #3
1135	off0_pt4	float	----- sensor #4
1137	off0_pt5	float	----- sensor #5
1139	off0_pt6	float	----- sensor #6
1141	off0_pt7	float	----- sensor #7
1143	off0_pt8	float	----- sensor #8
1145	off0_pt9	float	----- sensor #9
1147	off0_pt10	float	----- sensor #10
1149	off0_pt11	float	----- sensor #11
1151	off0_pt12	float	----- sensor #12
1153	off0_pt13	float	----- sensor #13
1155	off0_pt14	float	----- sensor #14
1157	off0_pt15	float	----- sensor #15
1159	off0_pt16	float	----- sensor #16
1161	off1_pt1	float	Physical offset[°C] of the 2nd calibration point of Pt100 sensor #1
1163	off1_pt2	float	----- sensor #2
1165	off1_pt3	float	----- sensor #3
1167	off1_pt4	float	----- sensor #4
1169	off1_pt5	float	----- sensor #5
1171	off1_pt6	float	----- sensor #6
1173	off1_pt7	float	----- sensor #7
1175	off1_pt8	float	----- sensor #8
1177	off1_pt9	float	----- sensor #9
1179	off1_pt10	float	----- sensor #10
1181	off1_pt11	float	----- sensor #11
1183	off1_pt12	float	----- sensor #12
1185	off1_pt13	float	----- sensor #13
1187	off1_pt14	float	----- sensor #14
1189	off1_pt15	float	----- sensor #15
1191	off1_pt16	float	----- sensor #16
1193	raw0_ma1	long	raw a/d reading for 1st calibration point of 4 mA input #1
1195	raw0_ma2	long	----- input #2
1197	raw0_ma3	long	----- input #3
1199	raw0_ma4	long	----- input #4
1201	raw0_ma5	long	----- input #5

Modbus Address	Name	Type	Description
1203	raw0_ma6	long	----- input #6
1205	raw0_ma7	long	----- input #7
1207	raw0_ma8	long	----- input #8
1209	raw1_ma1	long	raw a/d reading for 2nd calibration point of 20 mA input #1
1211	raw1_ma2	long	----- input #2
1213	raw1_ma3	long	----- input #3
1215	raw1_ma4	long	----- input #4
1217	raw1_ma5	long	----- input #5
1219	raw1_ma6	long	----- input #6
1221	raw1_ma7	long	----- input #7
1223	raw1_ma8	long	----- input #8

A.2.3 Configuration

Block system parameters

Modbus Address	Name	Type	Description
2001	filter_pt	int	filter factor for Pt100 inputs. unit:[s]
2002	filter_ma	int	filter factor for mA inputs. unit: [s]
2003	com_addr	int	modbus interface address
2004	com_baud	int	modbus interface baud rate
2005	devi_name	char[8]	TTM unit name
2009	t_reg_sp	int	set point of internal temperature controller
2010	t_reg_p	int	proportional factor of internal temperature controller
2011	t_reg_i	int	integral time of internal temperature controller
2012	t_reg_cyc	int	cycle time of internal temperature controller
2013	Spare	int	
2014	bm_stat	int	Bm70/bm100 status
2015	bm_p_adr	int	Primary BM70/100 address
2016	bm_s_adr	int	Secondary BM70/100 address
2017	bm_p_ver	int	Primary BM70/100 version
2018	bm_s_ver	int	Secondary BM70/100 version
2019	sensor_id1	int	Remote sensor ID bits 15..0
2020	sensor_id2	int	Remote sensor ID bits 31..16
2021	sensor_id3	int	Remote sensor ID bits 47..32
2022	Spare	int	
2023	dsp_cycle	int	Display switching cycle. unit=0.1s
2024	dsp_count	int	Count of display switching. i.e. dsp_count=3 means display is switched between dsp1,dsp2,dsp3 and back to dsp0.
2025	dsp11_var	int	line 1 of display 1 - variable index -1 for 'text only' display
2026	dsp12_var	int	line 1 of display 2 - variable index
2027	dsp13_var	int	line 1 of display 3 - variable index
2028	dsp14_var	int	line 1 of display 4 - variable index
2029	dsp15_var	int	line 1 of display 5 - variable index
2030	dsp16_var	int	line 1 of display 6 - variable index
2031	dsp17_var	int	line 1 of display 7 - variable index
2032	dsp18_var	int	line 1 of display 8 - variable index
2033	dsp19_var	int	line 1 of display 9 - variable index
2034	dsp110_var	int	line 1 of display 10 - variable index
2035	dsp21_var	int	line 2 of display 1 - variable index

Modbus Address	Name	Type	Description
2036	dsp22_var	int	line 2 of display 2 - variable index
2037	dsp23_var	int	line 2 of display 3 - variable index
2038	dsp24_var	int	line 2 of display 4 - variable index
2039	dsp25_var	int	line 2 of display 5 - variable index
2040	dsp26_var	int	line 2 of display 6 - variable index
2041	dsp27_var	int	line 2 of display 7 - variable index
2042	dsp28_var	int	line 2 of display 8 - variable index
2043	dsp29_var	int	line 2 of display 9 - variable index
2044	dsp210_var	int	line 2 of display 10 - variable index
2045	dsp11_for	int	line 1 of display 1 - display format: bits 3..0 - variable display position. right justified. bits 6..4 - precision. applicable only to floating point variables (single,double)
2046	dsp12_for	int	line 1 of display 2 - display format:
2047	dsp13_for	int	line 1 of display 3 - display format:
2048	dsp14_for	int	line 1 of display 4 - display format:
2049	dsp15_for	int	line 1 of display 5 - display format:
2050	dsp16_for	int	line 1 of display 6 - display format:
2051	dsp17_for	int	line 1 of display 7 - display format:
2052	dsp18_for	int	line 1 of display 8 - display format:
2053	dsp19_for	int	line 1 of display 9 - display format:
2054	dsp110_for	int	line 1 of display 10 - display format:
2055	dsp21_for	int	line 2 of display 1 - display format:
2056	dsp22_for	int	line 2 of display 2 - display format:
2057	dsp23_for	int	line 2 of display 3 - display format:
2058	dsp24_for	int	line 2 of display 4 - display format:
2059	dsp25_for	int	line 2 of display 5 - display format:
2060	dsp26_for	int	line 2 of display 6 - display format:
2061	dsp27_for	int	line 2 of display 7 - display format:
2062	dsp28_for	int	line 2 of display 8 - display format:
2063	dsp29_for	int	line 2 of display 9 - display format:
2064	dsp210_for	int	line 2 of display 10 - display format:
2065	dsp11_txt	char[18]	line1 of display 1 - background text
2074	dsp12_txt	char[18]	line1 of display 2 - background text
2083	dsp13_txt	char[18]	line1 of display 3 - background text
2092	dsp14_txt	char[18]	line1 of display 4 - background text
2101	dsp15_txt	char[18]	line1 of display 5 - background text
2110	dsp16_txt	char[18]	line1 of display 6 - background text
2119	dsp17_txt	char[18]	line1 of display 7 - background text
2128	dsp18_txt	char[18]	line1 of display 8 - background text
2137	dsp19_txt	char[18]	line1 of display 9 - background text
2146	dsp110_txt	char[18]	line1 of display 10 - background text
2155	dsp21_txt	char[18]	line2 of display 1 - background text
2164	dsp22_txt	char[18]	line2 of display 2 - background text
2173	dsp23_txt	char[18]	line2 of display 3 - background text
2182	dsp24_txt	char[18]	line2 of display 4 - background text
2191	dsp25_txt	char[18]	line2 of display 5 - background text
2200	dsp26_txt	char[18]	line2 of display 6 - background text
2209	dsp27_txt	char[18]	line2 of display 7 - background text
2218	dsp28_txt	char[18]	line2 of display 8 - background text
2227	dsp29_txt	char[18]	line2 of display 9 - background text
2236	dsp210_txt	char[18]	line2 of display 10 - background text
2245	rel_stat	int	relay status
2246	dsp_contr	int	display contrast factor

Modbus Address	Name	Type	Description
2247	sbr_pt_min	float	pt100 sensor break limit low
2249	sbr_pt_max	float	pt100 sensor break limit hi
2251	br_ma_min	float	analogue input break limit low
2253	br_ma_max	float	analogue input break limit hi
2255	scph0_ma1	float	mA reading scaling point 1, input 1
2257	scph0_ma2	float	mA reading scaling point 1, input 2
2259	scph0_ma3	float	mA reading scaling point 1, input 3
2261	scph0_ma4	float	mA reading scaling point 1, input 4
2263	scph0_ma5	float	mA reading scaling point 1, input 5
2265	scph0_ma6	float	mA reading scaling point 1, input 6
2267	scph0_ma7	float	mA reading scaling point 1, input 7
2269	scph0_ma8	float	mA reading scaling point 1, input 8
2271	scph1_ma1	float	mA reading scaling point 2, input 1
2273	scph1_ma2	float	mA reading scaling point 2, input 2
2275	scph1_ma3	float	mA reading scaling point 2, input 3
2277	scph1_ma4	float	mA reading scaling point 2, input 4
2279	scph1_ma5	float	mA reading scaling point 2, input 5
2281	scph1_ma6	float	mA reading scaling point 2, input 6
2283	scph1_ma7	float	mA reading scaling point 2, input 7
2285	scph1_ma8	float	mA reading scaling point 2, input 8
2287	sceu0_ma1	float	value in E.U. scaling point 1, input 1
2289	sceu0_ma2	float	value in E.U. scaling point 1, input 2
2291	sceu0_ma3	float	value in E.U. scaling point 1, input 3
2293	sceu0_ma4	float	value in E.U. scaling point 1, input 4
2295	sceu0_ma5	float	value in E.U. scaling point 1, input 5
2297	sceu0_ma6	float	value in E.U. scaling point 1, input 6
2299	sceu0_ma7	float	value in E.U. scaling point 1, input 7
2301	sceu0_ma8	float	value in E.U. scaling point 1, input 8
2303	sceu1_ma1	float	value in E.U. scaling point 2, input 1
2305	sceu1_ma2	float	value in E.U. scaling point 2, input 2
2307	sceu1_ma3	float	value in E.U. scaling point 2, input 3
2309	sceu1_ma4	float	value in E.U. scaling point 2, input 4
2311	sceu1_ma5	float	value in E.U. scaling point 2, input 5
2313	sceu1_ma6	float	value in E.U. scaling point 2, input 6
2315	sceu1_ma7	float	value in E.U. scaling point 2, input 7
2317	sceu1_ma8	float	value in E.U. scaling point 2, input 8
2319	hart1_dev	int	HART#1 device description. bits 0..7 manufacturer code, bits 8..15 device code
2320	hart2_dev	int	HART#2 device description. bits 0..7 manufacturer code, bits 8..15 device code
2321	hart1_id	long int	HART #1 device identifier bits 0..23 val.0 - automatic recognition
2323	hart2_id	long int	HART #2 device identifier bits 0..23 val.0 - automatic recognition
2325	hart1_span	float	span factor for hart PV accommodation for HART chan #1 (default 1.000)
2327	hart2_span	float	span factor for hart PV accommodation for HART chan #2 (default 1.000)
2329	hart1_zero	float	offset factor for hart PV accommodation for HART chan #1 (default 0.000)
2331	hart2_zero	float	offset factor for hart PV accommodation for HART chan #2 (default 0.000)

Block Configuration

Mod. Addr.	Name	Type	Unit	Description
5001	L _{T1}	Uint	mm	Distance to flange
5002	L _{T2}	Uint	mm	Distance to flange
5003	L _{T3}	Uint	mm	Distance to flange
5004	L _{T4}	Uint	mm	Distance to flange
5005	L _{T5}	Uint	mm	Distance to flange
5006	L _{T6}	Uint	mm	Distance to flange
5007	L _{T7}	Uint	mm	Distance to flange
5008	L _{T8}	Uint	mm	Distance to flange
5009	L _{T9}	Uint	mm	Distance to flange
5010	L _{T10}	Uint	mm	Distance to flange
5011	L _{T11}	Uint	mm	Distance to flange
5012	L _{T12}	Uint	mm	Distance to flange
5013	L _{T13}	Uint	mm	Distance to flange
5014	L _{T14}	Uint	mm	Distance to flange
5015	L _{T15}	Uint	mm	Distance to flange
5016	L _{T16}	Uint	mm	Distance to flange
5017	T _{i,on/off}	int	-	On/Off status of Pt100
5018	ASP1A	int	-	Input assignment
5019	ASP1B	int	-	Input assignment
5020	ASP2	int	-	Input assignment
5021	ASP3	int	-	Input assignment
5022	ASTAVV	int	-	Input assignment
5023	ASTAVP	int	-	Input assignment
5024	ASTAVW	int	-	Input assignment
5025	ASLVL1	int	-	Input assignment
5026	ASINT1	int	-	Input assignment
5027	ASLVL2	int	-	Input assignment
5028	ASINT2	int	-	Input assignment
5029	ASACTD	int	-	Input assignment
5030	ASREFD	int	-	Input assignment
5031	ASProof	int	-	Input assignment
5032	ASTout	int	-	Input assignment
5033	Tanktype	int	-	Shape of the tank
5034	FRCtype	int	-	Roof weight correction
5035	STWctype	int	-	Stilling well correction
5036	SEctype	int	-	Tank shell correction
5037	Bctype	int	-	Bulging correction.
5038	CalcMethod	int	-	Calculation method for VCF
5039	PressType	int	-	Type of pressure measurement
5040	AI _{on/off}	int	-	On/Off status of Analogue inputs
5041	Spare	int	-	
5042	Refcond	int	-	Standard or no standard reference conditions
5043	VCFtype	int	-	With temperature and/or pressure
5044	Producttype	int	-	Type of product in the tank
5045	MSK1PTOPEN	int	-	Relay 1 Mask pt100 open
5046	MSK1PTSHORT	int	-	Relay 1 Mask pt100 short
5047	MSK1AIER	int	-	Relay 1 Mask analog input errors
5048	MSK1CLVL	int	-	Relay 1 Mask level calc alarms
5049	MSK1CTMP	int	-	Relay 1 Mask temp. calc alarms
5050	MSK1INITERR	int	-	Relay 1 Mask TTM100 init err
5051	Spare	int	-	

Mod. Addr.	Name	Type	Unit	Description
5052	Spare	int	-	
5053	MSK1CPRS	int	-	Relay 1 Mask pres. calc alarms
5054	MSK1STRP	int	-	Relay 1 Mask strapping table alarms
5055	MSK1FRC	int	-	Relay 1 Mask Floating roof alarms
5056	MSK1CDNS	int	-	Relay 1 Mask dens. calc alarms
5057	MSK1CAPI	int	-	Relay 1 Mask API calc alarms
5058	Spare	int	-	
5059	MSK1LVL	int	-	Relay 1 Mask level alarms
5060	MSK1INT	int	-	Relay 1 Mask interface alarms
5061	MSK1TAVVAP	int	-	Relay 1 Mask TAVVAP
5062	MSK1TAVPROD	int	-	Relay 1 Mask TAVPROD
5063	MSK1TAVWATER	int	-	Relay 1 Mask TAVWATER
5064	MSK1PRES	int	-	Relay 1 Mask pressure alarms
5065	MSK2PTOPEN	int	-	Relay 2 Mask pt100 open
5066	MSK2PTSHORT	int	-	Relay 2 Mask pt100 short
5067	MSK2AIER	int	-	Relay 2 Mask analog input errors
5068	MSK2CLVL	int	-	Relay 2 Mask level calc alarms
5069	MSK2CTMP	int	-	Relay 2 Mask temp. calc alarms
5070	MSK2INITERR	int	-	Relay 2 Mask TTM100 init err
5071	Spare	int	-	
5072	Spare	int	-	
5073	MSK2CPRS	int	-	Relay 2 Mask pres. calc alarms
5074	MSK2STRP	int	-	Relay 2 Mask strapping table alarms
5075	MSK2FRC	int	-	Relay 2 Mask Floating roof alarms
5076	MSK2CDNS	int	-	Relay 2 Mask dens. calc alarms
5077	MSK2CAPI	int	-	Relay 2 Mask API calc alarms
5078	Spare	int	-	
5079	MSK2LVL	int	-	Relay 2 Mask level alarms
5080	MSK2INT	int	-	Relay 2 Mask interface alarms
5081	MSK2TAVVAP	int	-	Relay 2 Mask TAVVAP
5082	MSK2TAVPROD	int	-	Relay 2 Mask TAVPROD
5083	MSK2TAVWATER	int	-	Relay 2 Mask TAVWATER
5084	MSK2PRES	int	-	Relay 2 Mask pressure alarms
5085	MSK3PTOPEN	int	-	Supervisory Mask pt100 open
5086	MSK3PTSHORT	int	-	Supervisory Mask pt100 short
5087	MSK3AIER	int	-	Supervisory Mask analog input errors
5088	MSK3CLVL	int	-	Supervisory Mask level calc alarms
5089	MSK3CTMP	int	-	Supervisory Mask temp. calc alarms
5090	MSK3INITERR	int	-	Supervisory Mask TTM100 init err
5091	Spare	int	-	
5092	Spare	int	-	
5093	MSK3CPRS	int	-	Supervisory Mask pres. calc alarms
5094	MSK3STRP	int	-	Supervisory Mask strapping table alarms
5095	MSK3FRC	int	-	Supervisory Mask Floating roof alarms
5096	MSK3CDNS	int	-	Supervisory Mask dens. calc alarms
5097	MSK3CAPI	int	-	Supervisory Mask API calc alarms
5098	Spare	int	-	
5099	MSK3LVL	int	-	Supervisory Mask level alarms
5100	MSK3INT	int	-	Supervisory Mask interface alarms
5101	MSK3TAVVAP	int	-	Supervisory Mask TAVVAP
5102	MSK3TAVPROD	int	-	Supervisory Mask TAVPROD
5103	MSK3TAVWATER	int	-	Supervisory Mask TAVWATER
5104	MSK3PRES	int	-	Supervisory Mask pressure alarms

A.2.4 Parameters

Block Tank Parameters

Modb. Addr.	Name	Type	Unit	Description
3001	H _{tank}	Uint	mm	Tank Height
3002	H _{stwell1}	Uint	mm	Height of the primary level stilling well
3003	H _{stwell2}	Uint	mm	Height of the secondary level stilling well
3004	H _{stwellT}	Uint	mm	Height of the temp probe stilling well
3005	H _{support}	Uint	mm	Height of roof support in floating roof tanks
3006	H _{takeoff}	Uint	mm	Height of level in stilling well when roof is lifted from its support
3007	Spare	float		
3009	Spare	float		
3011	REFPRESS	float	kPa	Reference pressure. As an absolute value default 101.325
3013	REFTEMP	float	°C	Reference temperature
3015	REFTEMP _{SEC}	float	°C	Reference temperature for shell expansion calculation
3017	REFTEMP _{STWEC}	float	°C	Reference temperature for stilling well expansion calculation
3019	STWEC	float	°C ⁻¹	Stilling well expansion coefficient
3021	SEC	float	°C ⁻¹	Shell expansion coefficient
3023	WROOF	float	Kg	Roof Weight
3025	D _a	float	Kg/m ³	Density of air
3027	TB	float	-	Bulging correction
3029	PSWHIGH	float	kPa	Pressure P1B high switchover
3031	PSWLOW	float	kPa	Pressure P1B low switchover
3033	V _{tank}	float	M ³	Total Tank volume
3035	MAXC	float	m ³	Maximum capacity of the storage tank
3037	Maintenance	int	-	0 = in operation, 1 = in maintenance
3038	Spare	-	-	
3039	g	float	-	Gravity acceleration
3041	K ₀	float	-	K – factor for free fill in
3045	K ₁	float	-	K – factor for free fill in
3049	K ₂	float	-	K – factor for free fill in
3053	E	float	N/m ²	Young's modulus of elasticity
3055	H _{P1A}	float	mm	Height of the pressure transmitter P1A
3057	H _{P1B}	float	mm	Height of the pressure transmitter P1B
3059	DBTC _{UPPER}	float	mm	Upper limit dead band temperature calculation
3061	DBTC _{LOWER}	float	mm	Lower limit dead band temperature calculation
3063	Productname	char(16)		Name of stored product

Block Alarm Limits

Modb. Addr.	Name	Type	Unit	Description
4001	LoLoLVL	float	mm	Lolo alarm limit for level
4003	LoLVL	float	mm	Lo alarm limit for level
4005	HiLVL	float	mm	Hi alarm limit for level
4007	HiHiLVL	float	mm	HiHi alarm limit for level
4009	HystLVL	float	mm	Hysteresis alarm limit for level
4011	LoLoINT	float	mm	Lolo alarm limit for interface

Modb. Addr.	Name	Type	Unit	Description
4013	LoINT	float	mm	Lo alarm limit for interface
4015	HiINT	float	mm	Hi alarm limit for interface
4017	HiHiINT	float	mm	HiHi alarm limit for interface
4019	HystINT	float	mm	Hysteresis alarm limit for interface
4021	LoLoTAVVAP	float	℃	Lolo alarm limit for volume weighted average temperature of vapour
4023	LoTAVVAP	float	℃	Lo alarm limit for volume weighted average temperature of vapour
4025	HiTAVVAP	float	℃	Hi alarm limit for volume weighted average temperature of vapour
4027	HiHiTAVVAP	float	℃	HiHi alarm limit for volume weighted average temperature of vapour
4029	HystTAVVAP	float	℃	Hysteresis alarm limit for volume weighted average temperature of vapour
4031	LoLoTAVPROD	float	℃	Lolo alarm limit for volume weighted average temperature of product
4033	LoTAVPROD	float	℃	Lo alarm limit for volume weighted average temperature of product
4035	HiTAVPROD	float	℃	Hi alarm limit for volume weighted average temperature of product
4037	HiHiTAVPROD	float	℃	HiHi alarm limit for volume weighted average temperature of product
4039	HystTAVPROD	float	℃	Hysteresis alarm limit for volume weighted average temperature of product
4041	LoLoTAVWATER	float	℃	Lolo alarm limit for volume weighted average temperature of sediment and water
4043	LoTAVWATER	float	℃	Lo alarm limit for volume weighted average temperature of sediment and water
4045	HiTAVWATER	float	℃	Hi alarm limit for volume weighted average temperature of sediment and water
4047	HiHiTAVWATER	float	℃	HiHi alarm limit for volume weighted average temperature of sediment and water
4049	HystTAVWATER	float	℃	Hysteresis alarm limit for volume weighted average temperature of sediment and water
4051	LoLoPRESS	float	kPa	Lolo alarm limit for pressure
4053	LoPRESS	float	kPa	Lo alarm limit for pressure
4055	HiPRESS	float	kPa	Hi alarm limit for pressure
4057	HiHiPRESS	float	kPa	HiHi alarm limit for pressure
4059	HystPRESS	float	kPa	Hysteresis alarm limit for pressure

Block Override Values

Mod. Addr.	Name	Type	Unit	Description
6001	p1a	float		Override for wide range pressure transmitter
6003	p1b	float		Override for small range pressure transmitter
6005	p2	float		(future)
6007	p3	float		Override for vapour pressure
6009	tav_vap	float		Override for volume weighted vapour temperature
6011	tav_prod	float		Override for volume weighted product temperature
6013	tav_water	float		Override for volume weighted water temperature
6015	tav_vap_l	float		Override for linear weighted vapour temperature

A Communication

6017	tav_prod_l	float		Override for linear weighted product temperature
6019	tav_water_l	float		Override for linear weighted water temperature
6021	level_1	float		Override for primary level
6023	interface_1	float		Override for primary interface
6025	level_2	float		Override for secondary level
6027	interface_2	float		Override for secondary interface
6029	act_dens	float		Override for actual density
6031	ref_dens	float		Override for reference density

Block Strapping Table

Mod. Addr.	Name	Type	Unit	Description
10001	point_cnt	int	-	number of points
10002	Height_0	Uint	mm	point#0 cumulative height
10003	Height_1	Uint	mm	point#1 cumulative height
.....	
12000	Height_1998	Uint	mm	point#1998 cumulative height
12001	Height_1999	Uint	mm	point#1999 cumulative height
12002	vol_0	float	m3	point#0 cumulative volume
12004	vol_1	float	m3	point#1 cumulative volume
...	
15998	vol_1998	float	m3	point#1998 cumulative volume
16000	vol_1999	float	m3	point#1999 cumulative volume

A.2.5 Measured data

Block Measured Data

Modb. Addr.	Name	Type	Unit	Description	dsp. idx.
1001	T1	float	℃	TTM100 reading	24
1003	T2	float	℃	TTM100 reading	25
1005	T3	float	℃	TTM100 reading	26
1007	T4	float	℃	TTM100 reading	27
1009	T5	float	℃	TTM100 reading	28
1011	T6	float	℃	TTM100 reading	29
1013	T7	float	℃	TTM100 reading	30
1015	T8	float	℃	TTM100 reading	31
1017	T9	float	℃	TTM100 reading	32
1019	T10	float	℃	TTM100 reading	33
1021	T11	float	℃	TTM100 reading	34
1023	T12	float	℃	TTM100 reading	35
1025	T13	float	℃	TTM100 reading	36
1027	T14	float	℃	TTM100 reading	37
1029	T15	float	℃	TTM100 reading	38
1031	T16	float	℃	TTM100 reading	39
1033	AI1	float	E.U.	Reading input 1 in eng. units	40
1035	AI2	float	E.U.	Reading input 2 in eng. units	41
1037	AI3	float	E.U.	Reading input 3 in eng. units	42
1039	AI4	float	E.U.	Reading input 4 in eng. units	43
1041	AI5	float	E.U.	Reading input 5 in eng. units	44
1043	AI6	float	E.U.	Reading input 6 in eng. units	45
1045	AI7	float	E.U.	Reading input 7 in eng. units	46
1047	AI8	float	E.U.	Reading input 8 in eng. units	47

Modb. Addr.	Name	Type	Unit	Description	dsp. idx.
1049	temp_int	float	°C	Internal Temperature of TTM100 electronics	87

A.2.6 Calculated data

Block Calculated Data

Modb. Addr.	Name	Type	Unit	Description	dsp. idx.
4001	P1A	float	kPa	Wide range P1 reading	48
4003	P1B	float	kPa	Small range P1 reading	49
4005	P1	float	kPa	P1 reading	50
4007	TAVPROD	float	°C	Volume Weighted Average Temperature of product	65
4009	TAVVAP	float	°C	Volume Weighted Average Temperature of vapour room	66
4011	TAVWATER	float	°C	Volume Weighted Average Temperature of water layer	67
4013	CorrLevel	float	Mm	Level used and corrected for stilling well expansion	59
4015	CorrInterface	float	Mm	Interface used and corrected for stilling well expansion	60
4017	LevelUsed	int	-	Selected instrument : bit0 - product level: 0 = primary, 1 = secondary. bit1 - interface level: 0= primary, 1 = secondary	61
4018	PressureUsed	int	-	Selected pressure transmitter 1 = P1A, 2 = P1B	68
4019	H _{P1}	float	Mm	Height of selected pressure transmitter	69
4021	PAVPROD	float	kPa	Average product pressure	70
4023	RC	float	m ³	Roof correction	71
4025	TOV	float	m ³	Total Observed Volume (product and water)	72
4027	GOV	float	m ³	Gross Observed Volume	73
4029	AR	float	m ³	Available room or Ullage volume	74
4031	FWV	float	m ³	Free Water Volume	75
4033	VRV	float	m ³	Vapour Room Volume	76
4035	VCF	float	-	Volume Correction Factor between REFDENS and ACTDENS	77
4037	P2	float	kPa	P2 reading (future)	51
4039	P3	float	kPa	P3 (vapour) reading	52
4041	ACTDENS	float	kg/m ³	Actual Density	78
4043	REFDENS	float	kg/m ³	Density at reference conditions (When calculated)	79
4045	DENS ₁₅	float	kg/m ³	Density at 15 °C	80
4047	GSV	float	m ³	Gross Standard Volume	81
4049	MASS	float	Kg	Total Mass of product	82
4051	prod_type	int	--	copy of reg. 5044 -Producttype	83
4052	Level1	float	mm	Primary level reading	53
4054	Level2	float	mm	Secondary level reading	54
4056	Interface1	float	mm	Primary Interface reading	55
4058	Interface2	float	mm	Secondary Interface reading	56
4060	Level	float	mm	Used level reading	57
4062	Interface	float	mm	Used Interface reading	58

Modb. Addr.	Name	Type	Unit	Description	dsp. idx.
4064	TB	float	-	if (5037 BCType != 0) then copy of 3027 - TB (tank par.) else 0	84
4066	Productname	char(16)		Name of stored product (for local display use)	85
4074	Maintenance	Int		0 = tank in operation, 1 = tank in maintenance mode (for local display use)	86

A.2.7 Alarms

Block Alarms

Mod. Addr.	Name	Type	Unit	Description
6001	T _{open}	int	-	Error status of Pt100 Open
6002	T _{short}	int	-	Error status of Pt100 Shortcut
6003	AI _{error}	int	-	Error status of analog input
6004	ALCALCLEVEL	int	-	Level acquisition alarm
6005	ALCALCTEMP	int	-	Temperature calculation alarm
6006	init_err	int	-	initialisation status:
6007	Spare	int	-	
6008	Spare	int	-	
6009	ALCALCP	int	-	Pressure calculation errors
6010	ALSTRAP	int	-	Strapping table alarms
6011	ALFRC	int	-	Floating roof correction alarms
6012	ALDENS	int	-	Density calculation alarms
6013	ALAPI2540	int	-	API2540 calculation alarms
6014	Spare	int	-	
6015	ALLVL	int	-	Limit alarm on level
6016	ALINT	int	-	Limit alarm on interface
6017	ALTAVVAP	int	-	Limit alarm on TAVVAP
6018	ALTAVPROD	int	-	Limit alarm on TAVPROD
6019	ALTAVWATER	int	-	Limit alarm on TAVWATER
6020	ALPRESS	int	-	Limit alarm on avg pressure
6021	P_gloHwError	int	-	Primary BM70 Hardware Errors
6022	P_gloError_1	int	-	Primary BM70 Errors
6023	P_gloWarning	int	-	Primary BM70 Markers (Warnings)
6024	P_vcoStatus	int	-	Primary BM70 VCO Status
6025	S_gloHwError	int	-	Secondary BM70 Hardware Errors
6026	S_gloError_1	int	-	Secondary BM70 Errors
6027	S_gloWarning	int	-	Secondary BM70 Markers (Warnings)
6028	S_vcoStatus	int	-	Secondary BM70 VCO Status
6029	P_hw_error	Int	-	Primary BM100 Hardware Errors
6030	P_sign_err	Int	-	Primary BM100 Signal Errors
6031	P_warnings	Int	-	Primary BM100 Markers (Warnings)
6032	S_hw_error	Int	-	Secondary BM100 Hardware Errors
6033	S_sign_err	Int	-	Secondary BM100 Signal Errors
6034	S_warnings	Int	-	Secondary BM100 Markers (Warnings)

A.2.8 Diagnostics

Block Diagnostics

Mod. Addr.	Name	Type	Unit	Description
5001	Sort_H _{T1}	Uint	mm	Sorted T1 element height
5002	Sort_H _{T2}	Uint	mm	Sorted T2 element height
5003	Sort_H _{T3}	Uint	mm	Sorted T3 element height
5004	Sort_H _{T4}	Uint	mm	Sorted T4 element height
5005	Sort_H _{T5}	Uint	mm	Sorted T5 element height
5006	Sort_H _{T6}	Uint	mm	Sorted T6 element height
5007	Sort_H _{T7}	Uint	mm	Sorted T7 element height
5008	Sort_H _{T8}	Uint	mm	Sorted T8 element height
5009	Sort_H _{T9}	Uint	mm	Sorted T9 element height
5010	Sort_H _{T10}	Uint	mm	Sorted T10 element height
5011	Sort_H _{T11}	Uint	mm	Sorted T11 element height
5012	Sort_H _{T12}	Uint	mm	Sorted T12 element height
5013	Sort_H _{T13}	Uint	mm	Sorted T13 element height
5014	Sort_H _{T14}	Uint	mm	Sorted T14 element height
5015	Sort_H _{T15}	Uint	mm	Sorted T15 element height
5016	Sort_H _{T16}	Uint	mm	Sorted T16 element height
5017	Temp _{T1}	float	°C	Temp of T1 Sorted Pt100
5019	Temp _{T2}	float	°C	Temp of T1 Sorted Pt100
5021	Temp _{T3}	float	°C	Temp of T1 Sorted Pt100
5023	Temp _{T4}	float	°C	Temp of T1 Sorted Pt100
5025	Temp _{T5}	float	°C	Temp of T1 Sorted Pt100
5027	Temp _{T6}	float	°C	Temp of T1 Sorted Pt100
5029	Temp _{T7}	float	°C	Temp of T1 Sorted Pt100
5031	Temp _{T8}	float	°C	Temp of T1 Sorted Pt100
5033	Temp _{T9}	float	°C	Temp of T1 Sorted Pt100
5035	Temp _{T10}	float	°C	Temp of T1 Sorted Pt100
5037	Temp _{T11}	float	°C	Temp of T1 Sorted Pt100
5039	Temp _{T12}	float	°C	Temp of T1 Sorted Pt100
5041	Temp _{T13}	float	°C	Temp of T1 Sorted Pt100
5043	Temp _{T14}	float	°C	Temp of T1 Sorted Pt100
5045	Temp _{T15}	float	°C	Temp of T1 Sorted Pt100
5047	Temp _{T16}	float	°C	Temp of T1 Sorted Pt100
5049	pt_used	int	-	count of active used Pt elements
5050	tav_vap_l	float	°C	avr. vapour temp lin. weighted
5052	tav_prod_l	float	°C	avr. prod temp lin. weighted
5054	tav_interf_l	float	°C	avr. interf temp lin. weight ed
5056	tav_vap	float	°C	avr. vapour temp vol. weighted
5058	tav_prod	float	°C	avr. prod temp vol. weighted
5060	tav_interf	float	°C	avr. interf temp vol. weighted
5062	CT _{vapour}	float	-	Stilling well correction factor vapour part
5064	CT _{liquid}	float	-	Stilling well correction factor liquid part
5066	CT _{water}	float	-	Stilling well correction factor water part
5068	dH _{STW1}	float	-	Stilling well correction primary level
5070	dH _{STW2}	float	-	Stilling well correction secondary level
5072	dH _{STWT}	float	-	Stilling well correction temp probe
5074	CorrLevel1	float	mm	Level corrected for primary level stilling well expansion
5076	CorrInterface1	float	mm	Interface corrected for primary level stilling well expansion
5078	CorrLevel2	float	mm	Level corrected for secondary level stilling well

Mod. Addr.	Name	Type	Unit	Description
				expansion
5080	CorrInterface2	float	mm	Interface corrected for secondary level stilling well expansion
5082	CorrSTWTemp	float	mm	Corrected stilling well height of temp probe.
5084	V _{total}	float	m ³	Volume of water plus product derived from strapping table
5086	V _{product}	float	m ³	Volume of product derived from strapping table
5088	V _{vapour}	float	m ³	Volume of vapour room derived from strapping table
5090	V _{water}	float	m ³	Volume of water derived from strapping table
5092	F _{therm,product}	float	-	Shell expansion factor product section
5094	F _{therm,vap}	float	-	Shell expansion factor vapour section
5096	F _{therm,water}	float	-	Shell expansion factor water section
5098	VCF _{ACT15}	float	-	VCF between ACTDENS and DENS ₁₅
5100	C _{pl,ACT15}	float	-	Correction for pressure between ACTDENS and DENS ₁₅
5102	C _{tl,ACT15}	float	-	Correction for temperature between ACTDENS and DENS ₁₅
5104	VCF _{REF15}	float	-	VCF between REF DENS and DENS ₁₅
5106	C _{pl,REF15}	float	-	Correction for pressure between REF DENS and DENS ₁₅
5108	C _{tl,REF15}	float	-	Correction for temperature between REF DENS and DENS ₁₅
5110	VCF	float		Correction for temperature between REF DENS and ACTDENS
5112	K ₀	float	-	Used K factor
5114	K ₁	float	-	Used K factor
5116	K ₂	float	-	Used K factor
5118	hart1_pv	float	-	Hart #1 proc value (calibrated)
5120	hart2_pv	float	-	Hart #2 proc value (calibrated)
5122	last_hart1_err	int		last HART communication error code for channel #1 0 -all ok 1-no response 2-answer error 3-line busy 4-device status bad 5-invalid device/manufacture identifier (different as declared) 6-serial ID different
5123	last_hart2_err	int		last HART communication error code for channel #2 codes as for channel #1
5124	dens_p	float	kg/m ³	act density calculated from pressure
5126	last_bmerr	int	-	last error code for TTM-BM70/100 communication bit0 - message to long (buffer ovr. bit1 - checksum bad bit2 - bad device ID bit3 - bad device address bit4 - bad device version bit5 - incorrect message length bit6 - unknown function
5127	cur_ma1	float	mA	Actual current at an. input 1
5129	cur_ma2	float	mA	Actual current at an. input 2

Mod. Addr.	Name	Type	Unit	Description
5131	cur_ma3	float	mA	Actual current at an. input 3
5133	cur_ma4	float	mA	Actual current at an. input 4
5135	cur_ma5	float	mA	Actual current at an. input 5
5137	cur_ma6	float	mA	Actual current at an. input 6
5139	cur_ma7	float	mA	Actual current at an. input 7
5141	cur_ma8	float	mA	Actual current at an. input 8
5143	NM_T _{open}	int		non masked alarm T _{open}
5144	NM_T _{short}	int		non masked alarm T _{short}
5145	NM_AI _{error}	int		non masked alarm AI _{error}
5146	NM_ALCALCLEVEL	int		non masked alarm ALCALCLEVEL
5147	NM_ALCALCTEMP	int		non masked alarm ALCALCTEMP
5148	NM_init_err	int		non masked alarm init_err
5149	Spare	int		
5150	Spare	int		
5151	NM_ALCALCP	int		non masked alarm ALCALCP
5152	NM_ALSTRAP	int		non masked alarm ALSTRAP
5153	NM_ALFRC	int		non masked alarm ALFRC
5154	NM_ALDENS	int		non masked alarm ALDENS
5155	NM_ALAPI2540	int		non masked alarm ALAPI2540
5156	Spare	int		
5157	NM_ALLVL	int		non masked alarm ALLVL
5158	NM_ALINT	int		non masked alarm ALINT
5159	NM_ALTAVVAP	int		non masked alarm ALTAVVAP
5160	NM_ALTAVPROD	int		non masked alarm ALTAVPROD
5161	NM_ALTAVWATER	int		non masked alarm ALTAVWATER
5162	NM_ALPRESS	int		non masked alarm ALPRESS

Block HART Diagnostics

Mod. Addr.	Name	Type	Unit	Description
7001	Byte Count In	Int		Low level scan variable
7002	Error Count In	Int		Low level scan variable
7003	Byte Count Out	Int		Low level scan variable
7004	Error Count Out	Int		Low level scan variable
7005	Spare	Int		
7006	Input buffer [1,0]	Int		Input data buffer
.....			
7030	Input buffer [49,50]	Int		Input data buffer
7031	Output buffer [1,0]	Int		Output data buffer
.....			
7055	Output buffer [49,48]	Int		Output data buffer
7056	Last command	Int		1 = Status request 2 = PV request
7057	Channel Number	Int		Number of last channel scanned
7058	Device ID 1	Long		From parameter list or read from device
7060	Device ID 2	Long		
7062	Scan result	Int		Last scan result: <ul style="list-style-type: none"> • -1 = OK • 0 = No answer • 1 = answer pending • 2 = answer error
7063	Fault Count 1	Int		Fault counters for each scan

Mod. Addr.	Name	Type	Unit	Description
7064	Fault Count 2	Int		
7065	Fault Count 3	Int		
7066	Fault Count 4	Int		
7067	Status 1	Int		Control variable for send state-machine
7068	Status 2	Int		
7069	Raw PV 1			Process variable read from device (last succesful scan)
7071	Raw PV 2			
7073	Scan Status	Int		Status of scanned device (last successful scan)
7074	Scan Device	Int		Device code and manufacturer code of scanned device (last successful scan)
7075	Scan Device ID	Long		Device ID of scanned device (last successful scan)
7077	Scan PV			Process value of scanned device (last successful scan)

Block System Variables

Modbus Address	Name	Type	Access	Description
1	dev_id	int	RO	TTM100 device identifier. reading value 601 assure connected with a TTM100
2	ver_num	int	RO	Software version. Current software version is 100 (to be interpreted as 1.00)
3	dev_num	int	RO	device number. for future use as unique unit number. temporarily val. = 0
4	init_err	int	RO	initialisation status: bit0 - CRC-error reading first copy of calibration table from EEPROM bit1 - CRC-error reading second copy of calibration table. if bit 0 and 1 are set TTM has loaded default calibration values. bit2 - CRC-error reading first copy of parameter table from EEPROM bit3 - CRC-error reading second copy of parameter table. if bit 2 and 3 are set TTM has loaded default parameter table bit4 - tank parameters table bad, default loaded bit5 - alarm parameters set bad, default loaded bit6 - config parameters bad, default loaded bit7 - Display access error. this bit is set if display not connected or damaged. bit 8 - primary level controller access error bit 9 - secondary level controller access error bit 10 - HART chan#1 communication failed bit 11 - HART chan#2 communication failed (failure description in reg.14) bit12 - strapping table bad, default loaded bit13 - modbus overwrite table bad, default (=0) loaded bit 14 - sensor ID bad
5	param_wr	int	R/W	parameter write request flag. writing !=0 into this variable cause saving current parameter settings into EEPROM. this flag is reset after parameter write complete.

Modbus Address	Name	Type	Access	Description
6	calib_wr	int	R/W	calibration write request flag. writing !=0 into this variable cause saving current calibration settings into EEPROM. this flag is reset after calibration write complete
7	tank_wr	int	R/W	Tank parameters write request flag. writing !=0 into this variable cause saving current tank parameter settings into EEPROM. this flag is reset after tank parameters write complete
8	alarm_wr	int	R/W	alarm parameters write request flag. writing !=0 into this variable cause saving current tank parameter settings into EEPROM. this flag is reset after alarm parameters write complete
9	config_wr	int	R/W	configuration parameters write request flag. writing !=0 into this variable cause saving current tank parameter settings into EEPROM. this flag is reset after configuration parameters write complete
10	strap_wr	int	R/W	strapping table write request flag. writing !=0 into this variable cause saving current tank parameter settings into EEPROM. this flag is reset after strapping table write complete
11	modb_wr	int	R/W	modbus overwrite table write request flag. writing !=0 into this variable cause saving current modbus overwrite settings into EEPROM. this flag is reset after table write complete
12	Spare	int		
13	t_ctrl_out	int	RO	temperature controller output status: bit0 - heater 1, bit1 - heater 2
14	Spare	int		
15	bm_active	int	RO	active level control devices bit 8 - primary controller bit9 - secondary controller

Block Raw Data

Modb. Addr.	Name	Type	Description	dsp. idx
1	sens_id	int	Pt100 sensor unit identifier. reading value 600 assure the TTM100-sensor is connected	
2	sens_ver	int	software version of TTM100-sensor. current version is 100 (interpreted as 1.00)	
3	com_addr	int[3]	TTM100-sensor unique number (not supported yet. for future use)	
6	pt1_raw	long	current raw a/d reading of Pt100 #1	0
8	pt2_raw	long	current raw a/d reading of Pt100 #2	1
10	pt3_raw	long	current raw a/d reading of Pt100 #3	2
12	pt4_raw	long	current raw a/d reading of Pt100 #4	3
14	pt5_raw	long	current raw a/d reading of Pt100 #5	4
16	pt6_raw	long	current raw a/d reading of Pt100 #6	5
18	pt7_raw	long	current raw a/d reading of Pt100 #7	6
20	pt8_raw	long	current raw a/d reading of Pt100 #8	7
22	pt9_raw	long	current raw a/d reading of Pt100 #9	8
24	pt10_raw	long	current raw a/d reading of Pt100 #10	9
26	pt11_raw	long	current raw a/d reading of Pt100 #11	10
28	pt12_raw	long	current raw a/d reading of Pt100 #12	11

Modb. Addr.	Name	Type	Description	dsp. idx
30	pt13_raw	long	current raw a/d reading of Pt100 #13	12
32	pt14_raw	long	current raw a/d reading of Pt100 #14	13
34	pt15_raw	long	current raw a/d reading of Pt100 #15	14
36	pt16_raw	long	current raw a/d reading of Pt100 #16	15
38	ma1_raw	long	current raw a/d reading of mA input #1	16
40	ma 2_raw	long	current raw a/d reading of mA input #2	17
42	ma 3_raw	long	current raw a/d reading of mA input #3	18
44	ma 4_raw	long	current raw a/d reading of mA input #4	19
46	ma 5_raw	long	current raw a/d reading of mA input #5	20
48	ma 6_raw	long	current raw a/d reading of mA input #6	21
50	ma 7_raw	long	current raw a/d reading of mA input #7	22
52	ma 8_raw	long	current raw a/d reading of mA input #8	23
54	Loc_t_raw	long	current raw a/d reading of local temperature sensor	
56	pt1_filt	long	current filtered a/d reading of Pt100 #1	
58	pt2_filt	long	current filtered a/d reading of Pt100 #2	
60	pt3_filt	long	current filtered a/d reading of Pt100 #3	
62	pt4_filt	long	current filtered a/d reading of Pt100 #4	
64	pt5_filt	long	current filtered a/d reading of Pt100 #5	
66	pt6_filt	long	current filtered a/d reading of Pt100 #6	
68	pt7_filt	long	current filtered a/d reading of Pt100 #7	
70	pt8_filt	long	current filtered a/d reading of Pt100 #8	
72	pt9_filt	long	current filtered a/d reading of Pt100 #9	
74	pt10_filt	long	current filtered a/d reading of Pt100 #10	
76	pt11_filt	long	current filtered a/d reading of Pt100 #11	
78	pt12_filt	long	current filtered a/d reading of Pt100 #12	
80	pt13_filt	long	current filtered a/d reading of Pt100 #13	
82	pt14_filt	long	current filtered a/d reading of Pt100 #14	
84	pt15_filt	long	current filtered a/d reading of Pt100 #15	
86	pt16_filt	long	current filtered a/d reading of Pt100 #16	
88	ma1_filt	long	current filtered a/d reading of mA input #1	
90	ma2_filt	long	current filtered a/d reading of mA input #2	
92	ma3_filt	long	current filtered a/d reading of mA input #3	
94	ma4_filt	long	current filtered a/d reading of mA input #4	
96	ma5_filt	long	current filtered a/d reading of mA input #5	
98	ma6_filt	long	current filtered a/d reading of mA input #6	
100	ma7_filt	long	current filtered a/d reading of mA input #7	
102	ma8_filt	long	current filtered a/d reading of mA input #8	

Block Primary BM70 Data

Modb. Addr.	Name	Type	Databl. Krohne	Description
2001	Version	char[16]	0	
2009	identNo	char[16]	0	
2017	tagName	char[16]	0	
2025	serialNo	char[16]	-	
2033	Commission	char[16]	-	
2041	valVolume	double	7	
2045	valLevel	double	7	
2049	valDistance	double	7	
2053	gloHwError	int	7	
2054	gloError_1	int	7	
2055	gloWarning	int	7	

Modb. Addr.	Name	Type	Databl. Krohne	Description
2056	gloStatus	int	7	
2057	vcoStatus	int	7	
2058	vcoStatus	int	7	
2059	sysFlags	int	-	
2060	dispUnit	int	7	
2061	unitLength	int	-	
2062	unitVolume	int	-	

Block Secondary BM70 Data

Modb. Addr.	Name	Type	Databl. Krohne	Description
2063	Version	char[16]	0	
2071	identNo	char[16]	0	
2079	tagName	char[16]	0	
2087	serialNo	char[16]	-	
2095	Commission	char[16]	-	
2103	valVolume	double	7	
2107	valLevel	double	7	Level in m
2111	valDistance	double	7	
2115	gloHwError	int	7	
2116	gloError_1	int	7	
2117	gloWarning	int	7	
2118	gloStatus	int	7	
2119	vcoStatus	int	7	
2120	vcoStatus	int	7	
2121	sysFlags	int	-	
2122	dispUnit	int	7	
2123	unitLength	int	-	
2124	unitVolume	int	-	

Block Primary BM100 Data

Modb. Addr.	Name	Type	Databl. Krohne	Description
3001	dev_ident	char[16]	0	
3009	sw_version	char[10]	0	
3014	tagName	char[16]	-	
3022	serialNo	char[16]	-	
3030	Commission	char[16]	-	
3038	valLevel	Float	1	Level in m
3040	level_magn	Int	1	Level Signal Magnitude
3041	level_gain	Int	1	Level Signal Gain
3041	ref_magn	Int	1	Reference Signal Magnitude
3043	ref_gain	Int	1	Reference Signal Gain
3044	val_if_level	float	2	Interface Level in m
3046	if_level_mag	Int	2	Interface Level Signal Magnitude
3047	if_level_gain	Int	2	Interface Level Signal Gain
3048	val_volume	float	3	Volume
3050	if_volume	float	3	Interface Volume
3052	ul_volume	float	3	Ullage Volume
3054	hw_error	Int	0x1f	Hardware Errors

Modb. Addr.	Name	Type	Databl. Krohne	Description
3055	sign_err	Int	0x1f	Signal Errors
3056	warnings	Int	0x1f	Markers (Warnings)
3057	Status	Int	0x1f	BM100 Status

Block Secondary BM100 Data

Modb. Addr.	Name	Type	Databl. Krohne	Description
3058	dev_ident	char[16]	0	
3066	sw_version	char[10]	0	
3071	tagName	char[16]	-	
3079	serialNo	char[16]	-	
3087	Commission	char[16]	-	
3095	valLevel	float	1	Level
3097	level_magn	Int	1	Level Signal Magnitude
3098	level_gain	Int	1	Level Signal Gain
3099	ref_magn	Int	1	Reference Signal Magnitude
3100	ref_gain	Int	1	Reference Signal Gain
3101	val_if_level	float	2	Interface Level
3103	if_level_mag	Int	2	Interface Level Signal Magnitude
3104	if_level_gain	Int	2	Interface Level Signal Gain
3105	val_volume	float	3	Volume
3107	if_volume	float	3	Interface Volume
3109	ul_volume	float	3	Ullage Volume
3111	hw_error	Int	0x1f	Hardware Errors
3112	sign_err	Int	0x1f	Signal Errors
3113	warnings	Int	0x1f	Markers (Warnings)
3114	status	Int	0x1f	BM100 Status

B Housing Dimensions

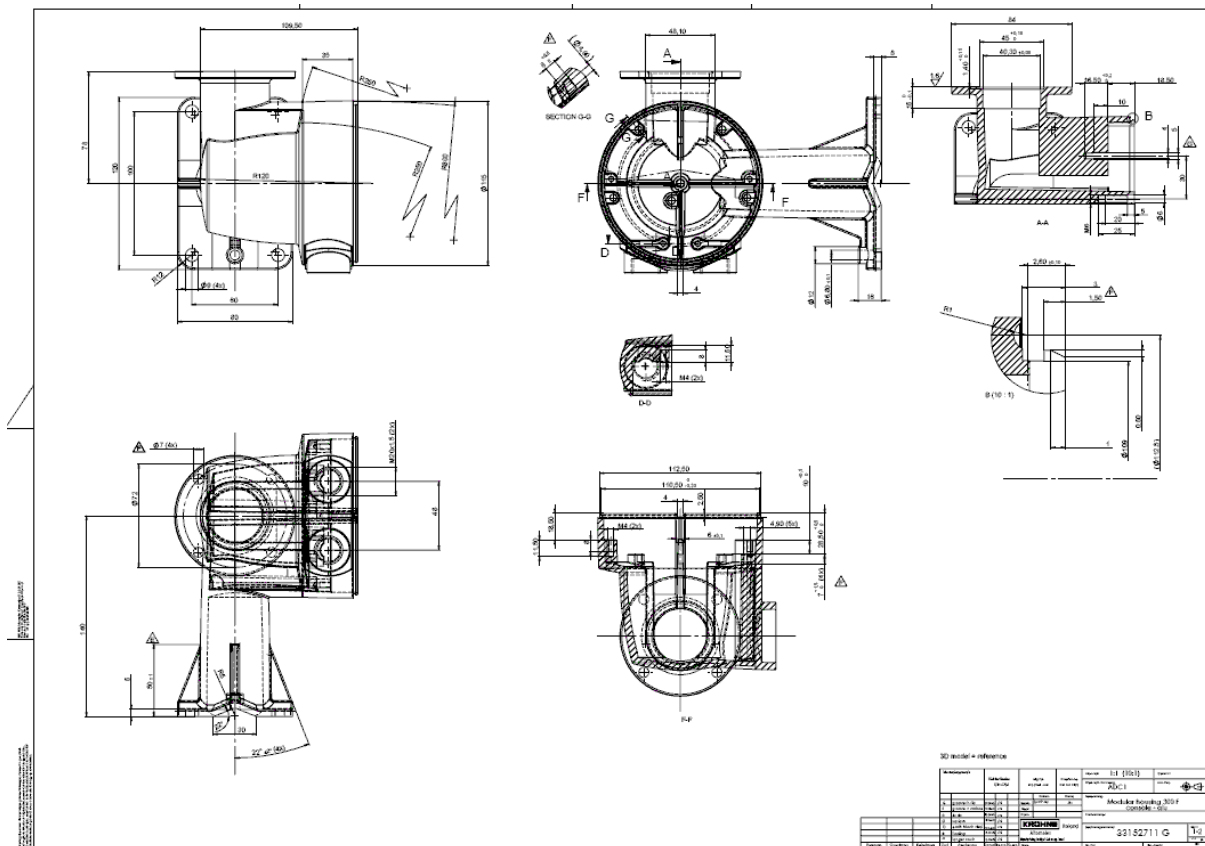
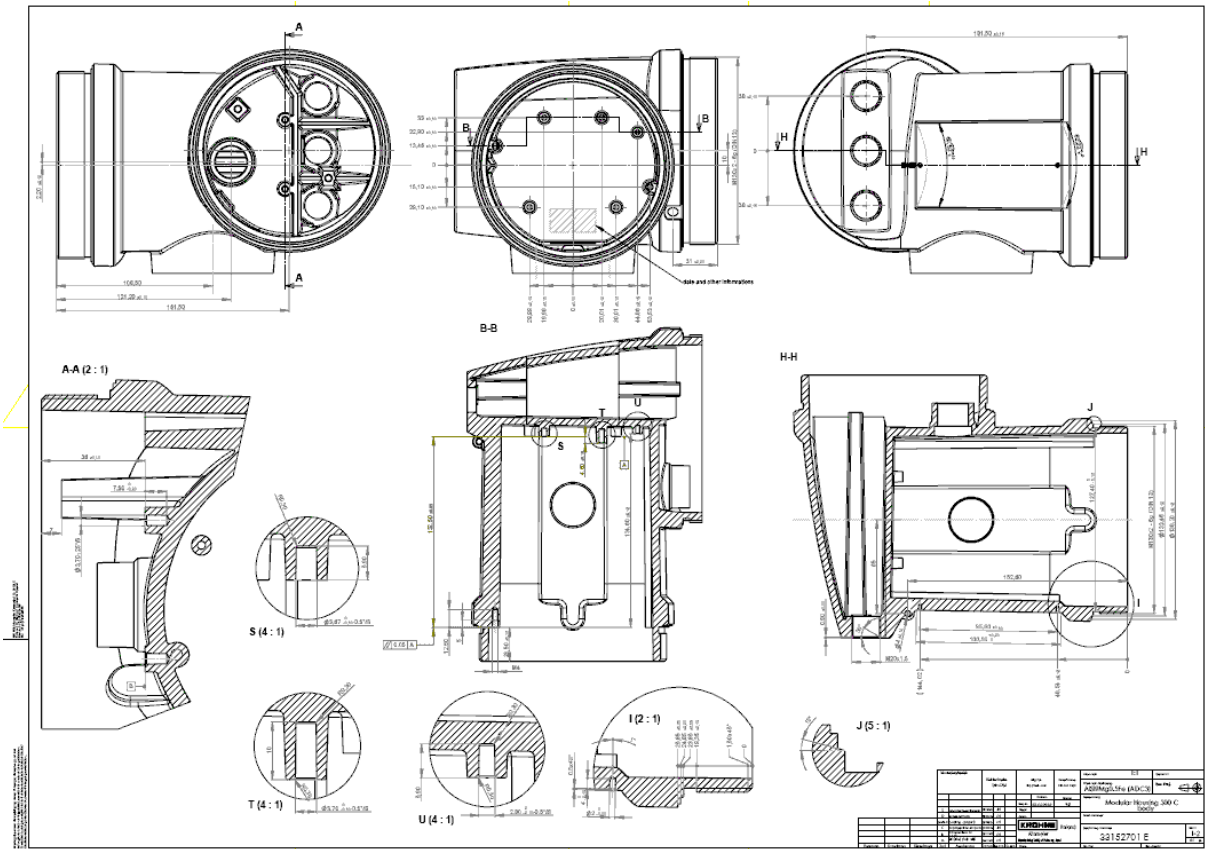

B Housing Dimensions

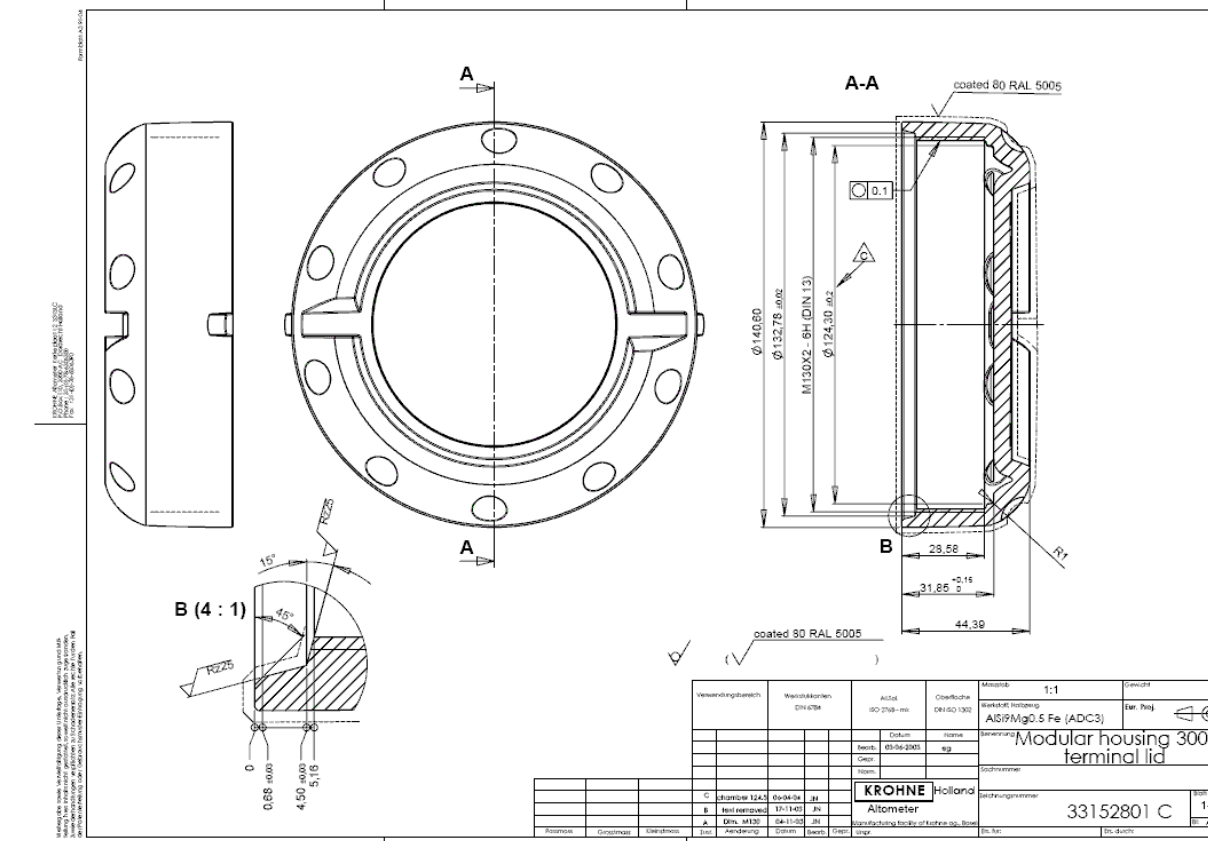
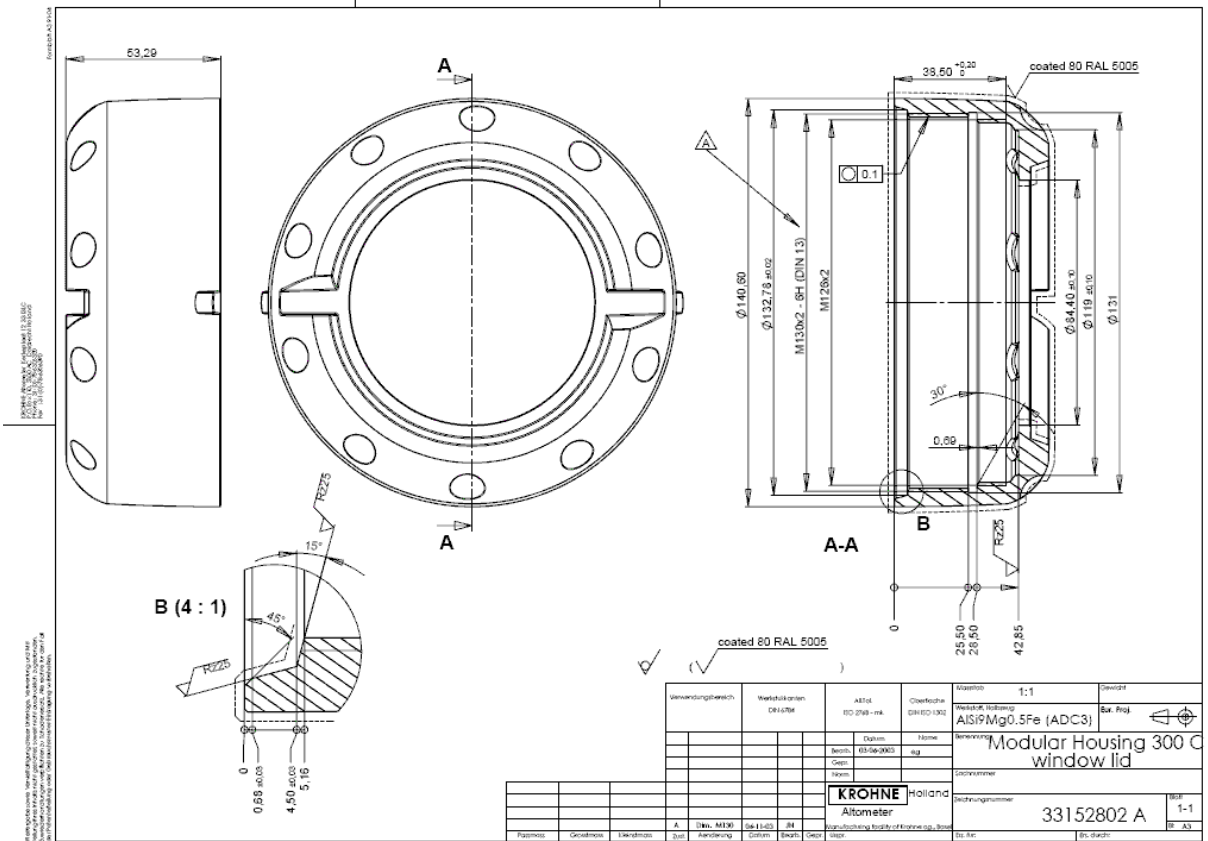

An example of a probe:

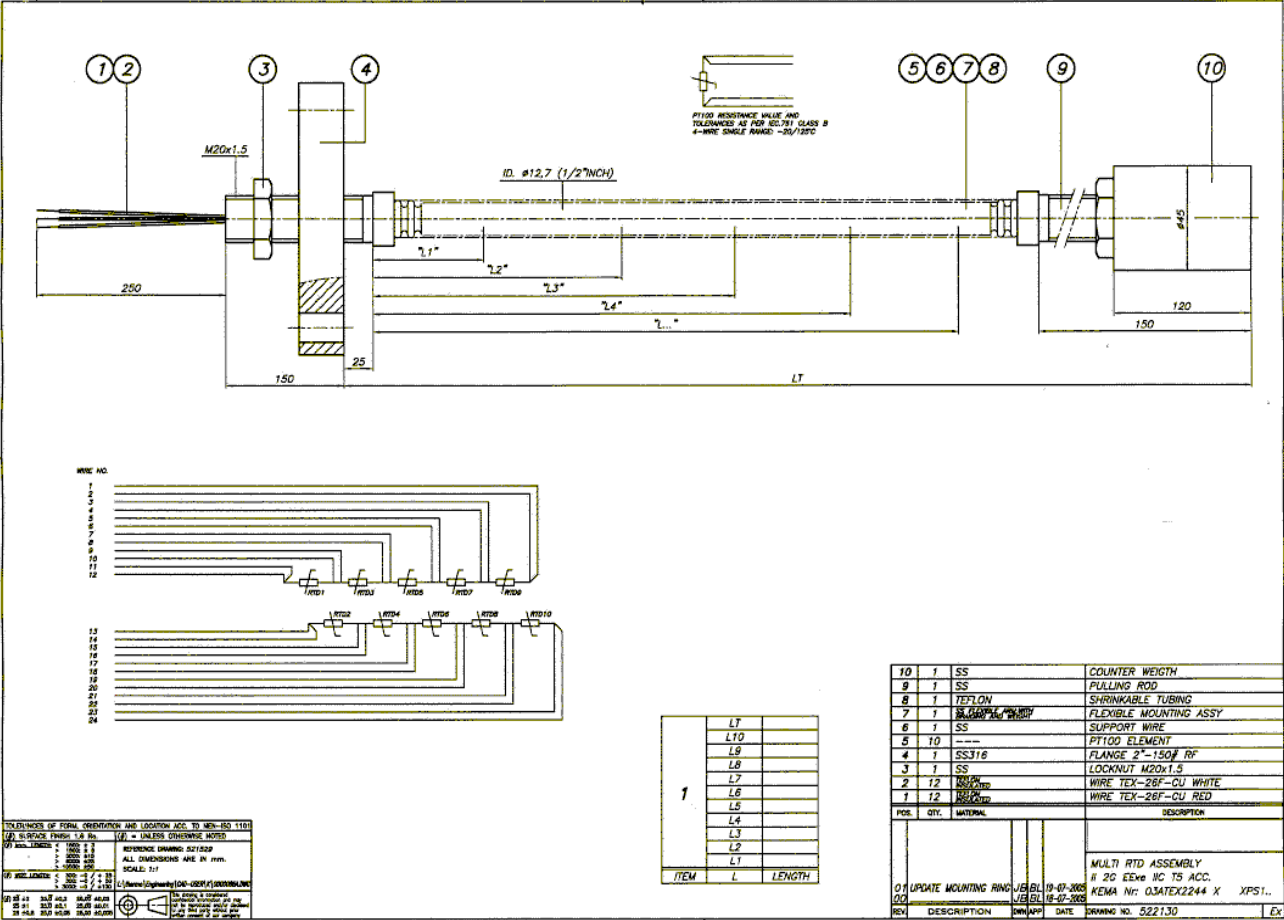



(1) **EG-Baumusterprüfbescheinigung**

(2) **- Richtlinie 94/9/EG -**
Geräte und Schutzsysteme zur bestimmungsgemäßen Verwendung
in explosionsgefährdeten Bereichen

(3) **BVS 05 ATEX E 124 X**

(4) **Gerät:** **Temperatursensor- und Transmitter-Multiplexer Typ TTM 100***

(5) **Hersteller:** **IBS BatchControl GmbH**

(6) **Anschrift:** **50170 Kerpen**

(7) Die Bauart dieses Gerätes sowie die verschiedenen zulässigen Ausführungen sind in der Anlage zu dieser Baumusterprüfbescheinigung festgelegt.

(8) Die Zertifizierungsstelle der EXAM BBG Prüf- und Zertifizier GmbH, benannte Stelle Nr. 0158 gemäß Artikel 9 der Richtlinie 94/9/EG des Europäischen Parlaments und des Rates vom 23. März 1994, bescheinigt, dass das Gerät die grundlegenden Sicherheits- und Gesundheitsanforderungen für die Konzeption und den Bau von Geräten und Schutzsystemen zur bestimmungsgemäßen Verwendung in explosionsgefährdeten Bereichen gemäß Anhang II der Richtlinie erfüllt.
Die Ergebnisse der Prüfung sind in dem Prüfprotokoll BVS PP 05.2092 EG niedergelegt.

(9) Die grundlegenden Sicherheits- und Gesundheitsanforderungen werden erfüllt durch Übereinstimmung mit
EN 50014:1997 + A1 – A2 Allgemeine Bestimmungen
EN 50018:2000 +A1 Druckfeste Kapselung 'd'
EN 50020:2002 Eigensicherheit 'i'

(10) Falls das Zeichen „X“ hinter der Bescheinigungsnummer steht, wird in der Anlage zu dieser Bescheinigung auf besondere Bedingungen für die sichere Anwendung des Gerätes hingewiesen.

(11) Diese EG-Baumusterprüfbescheinigung bezieht sich nur auf die Konzeption und die Baumusterprüfung des beschriebenen Gerätes in Übereinstimmung mit der Richtlinie 94/9/EG.
Für Herstellung und in Verkehr bringen des Gerätes sind weitere Anforderungen der Richtlinie zu erfüllen, die nicht durch diese Bescheinigung abgedeckt sind.

(12) Die Kennzeichnung des Gerätes muss die folgenden Angaben enthalten:

 **II 2G EEx ib/ia IIC T4** für Typ TTM 100A
II 2G EEx d[ib] IIC T4 für Typ TTM 100B

EXAM BBG Prüf- und Zertifizier GmbH

Bochum, den 30. August 2005

Zertifizierungsstelle

Fachbereich



(13) Anlage zur

(14) **EG-Baumusterprüfbescheinigung****BVS 05 ATEX E 124 X**(15) 15.1 Gegenstand und Typ

Temperatursensor- und Transmitter-Multiplexer Typ TTM 100*

Anstelle des * wird in der vollständigen Benennung der Buchstabe A oder B eingefügt, der unterschiedliche Gehäuse kennzeichnet.

15.2 Beschreibung

Der Temperatursensor- und Transmitter-Multiplexer besteht aus dem Transmitter Typ TTM 100B und dem Multiplexer Typ TTM 100A, die über eine bis zu 200 m lange Leitung miteinander verbunden sind. Die Geräte dienen zur Füllstandsüberwachung und Tankinhaltsberechnung eines Lagertanks.

Der Transmitter besteht aus dem Gehäuse Typ MH 300-EEEx (KEMA 03ATEX2527 U) und der darin gesichert befestigten elektronischen Schaltung. Die äußeren nicht-eigensicheren Stromkreise werden über gesondert bescheinigte Leitungseinführungen in das Anschlussgehäuse geführt.

In dem Transmittergehäuse ist wahlweise eine Heizung eingebaut, die die Gehäuseinnentemperatur auch bei Minustemperaturen auf 0 °C stabilisiert.

In dem Gehäuse des Multiplexers ist eine elektronische Schaltung zur Speisung und Auswertung von Transmitter- und PT100-Stromkreisen und zur Datenübertragung untergebracht.

15.3 Kenngrößen

15.3.1 Transmitter Typ TTM 100B

15.3.1.1 Netzstromkreis (Klemmen 18 und 19)

Bemessungsspannung		AC	115	V
max. Spannung	Um	AC/DC	125	V
oder				
Bemessungsspannung		AC	230	V
max. Spannung	Um	AC/DC	250	V

15.3.1.2 nicht eigensichere Relaiskontakt-Stromkreise (Klemmen 13 und 14 und 15 und 16)

Schaltspannung		DC	30	V
Schaltstromstärke			1	A
oder				
Schaltspannung		AC	125	V
Schaltstromstärke			0,5	A
max. Spannung	Um	AC/DC	125	V

15.3.1.3 nicht eigensichere Transmitter-Speisestromkreise (Klemmen 7 und 9, 8 und 9, 10 und 12 und 11 und 12)

Bemessungsspannung		DC	28	V
Stromstärke			50	mA
max. Spannung	Um	AC/DC	125	V

Seite 2 von 3 zu BVS 05 ATEX E 124 X
 Dieses Zertifikat darf nur unverändert weiterverbreitet werden.
 Dinnendahlstraße 9 44809 Bochum Telefon 0234/3696-105 Telefax 0234/3696-110



15.3.1.4	nicht eigensichere RS485-Schnittstelle (Klemmen 1 bis 6)				
	Bemessungsspannung		DC	6	V
	Stromstärke			100	mA
	max. Spannung	Um	AC/DC	48	V
15.3.1.5	eigensichere Ausgangsstromkreise (Klemmen 1 – 4) in der Zündschutzart EEx ib IIC				
	Us1 – GND, Us2 – GND				
	Spannung	Uo	DC	26	V
	Stromstärke	Io		58	mA
	RxD – GND				
	Spannung	Uo	DC	26	V
	Stromstärke	Io		8	mA
15.3.1.6	Umgebungstemperaturbereich	Ta		-40 °C bis +65 °C	
15.3.2	Multiplexer Typ TTM 100A				
15.3.2.1	Transmitterspeisestromkreise (Klemmen 20 bis 27) in der Zündschutzart EEx ia IIC				
	Spannung	Uo	DC	21,7	V
	Stromstärke	Io		90	mA
	Leistung	Po		584	mW
	trapezförmige Ausgangskennlinie				
	max. äußere Kapazität	Co		148	nF
	max. äußere Induktivität	Lo		4,3	mH
15.3.2.2	PT100-Stromkreise 1 bis 8 (Klemmen A1 bis A18) und 9 bis 16 (Klemmen B1 bis B18) in der Zündschutzart EEx ia IIC				
	Werte je Klemmenblock				
	Spannung	Uo	DC	5,3	V
	Stromstärke	Io		13,7	mA
	Leistung	Po		23	mW
	max. äußere Kapazität	Co		3	µF
	max. äußere Induktivität	Lo		50	mH
15.3.2.3	Umgebungstemperaturbereich	Ta		-40 °C bis +65 °C	

(16) Prüfprotokoll
BVS PP 05.2092 EG, Stand 30.08.2005

(17) Besondere Bedingungen für die sichere Anwendung

Der zulässige Umgebungstemperaturbereich für den Betrieb des Transmitters Typ TTM 100B und des Multiplexers Typ TTM 100A ist -40 °C bis +65 °C. Die Verwendung der Geräte in einer Umgebungstemperatur unter -20 °C ist zulässig, wenn für diese Temperatur geeignete Leitungen und für diesen Einsatz geeignete Kabel- oder Leitungseinführungen verwendet werden.



Translation

EC-Type Examination Certificate

- (1) **EC-Type Examination Certificate**
- (2) **- Directive 94/9/EC -**
Equipment and protective systems intended for use
in potentially explosive atmospheres
- (3) **BVS 05 ATEX E 124 X**
- (4) **Equipment:** Temperature sensor multiplexer and Transmitter type TTM 100*
- (5) **Manufacturer:** IBS BatchControl GmbH
- (6) **Address:** 50170 Kerpen, Germany
- (7) The design and construction of this equipment and any acceptable variation thereto are specified in the schedule to this type examination certificate.
- (8) The certification body of EXAM BBG Prüf- und Zertifizier GmbH, notified body no. 0158 in accordance with Article 9 of the Directive 94/9/EC of the European Parliament and the Council of 23 March 1994, certifies that this equipment has been found to comply with the Essential Health and Safety Requirements relating to the design and construction of equipment and protective systems intended for use in potentially explosive atmospheres, given in Annex II to the Directive.
The examination and test results are recorded in the test and assessment report BVS PP 05.2092 EG.
- (9) The Essential Health and Safety Requirements are assured by compliance with:
EN 50014:1997+A1-A2 General requirements
EN 50018:2000 +A1 Flameproof enclosure 'd'
EN 50020:2002 Intrinsic safety 'i'
- (10) If the sign "X" is placed after the certificate number, it indicates that the equipment is subject to special conditions for safe use specified in the schedule to this certificate.
- (11) This EC-Type Examination Certificate relates only to the design, examination and tests of the specified equipment in accordance to Directive 94/9/EC.
Further requirements of the Directive apply to the manufacturing process and supply of this equipment. These are not covered by this certificate
- (12) The marking of the equipment shall include the following:

 **II 2G EEx ib/ia IIC T4** für Typ TTM 100A
II 2G EEx d[ib] IIC T4 für Typ TTM 100B

EXAM BBG Prüf- und Zertifizier GmbH

Bochum, dated 30. August 2005

Signed: Dr. Jockers

Certification body

Signed: Dr. Eickhoff

Special services unit

Page 1 of 4 to BVS 05 ATEX E 124 X
This certificate may only be reproduced in its entirety and without change
Dinmendalestrasse 9 44809 Bochum Germany Phone +49 234/3696-105 Fax +49 234/3696-110



(13) Appendix to

(14) **EC-Type Examination Certificate****BVS 05 ATEX E 124 X**(15) 15.1 Subject and type

Temperature sensor multiplexer and transmitter type TTM 100*
 Instead of the * in the complete denomination the letter A or B will be inserted to characterize different apparatus.

15.2 Description

The temperature sensor multiplexer type TTM 100A and the transmitter type TTM 100B which work together, are connected by an up to 200 m long cable. The apparatus are used for level control and volume calculation of a storage tank.

The transmitter consists of an enclosure type MII 300-EEEx (KEMA 03ATEX2527 U) and the electronic circuitry mounted inside the enclosure. The external non-intrinsically safe circuits will be led into the connection enclosure by separately certified cable glands.

Inside the transmitter enclosure a heating device may be mounted to keep the temperature inside the enclosure at 0 °C even at minus outside temperatures.

In the enclosure of the multiplexer an electronic circuitry for supply and evaluation of transmitter and PT100 circuits and for data transmission is fastened.

15.3 Parameters

15.3.1 Transmitter Typ TTM 100B

15.3.1.1 Mains circuit (terminals 18 and 19)

Nominal voltage		AC	115	V
Max. voltage	Um	AC/DC	125	V
or				
Nominal voltage		AC	230	V
Max. voltage	Um	AC/DC	250	V

15.3.1.2 non intrinsically safe relay contact (terminals 13 and 14 and 15 and 16)

Switching voltage		DC	30	V
Switching current			1	A
or				
Switching voltage		AC	125	V
Switching current			0,5	A
Max. voltage	Um	AC/DC	125	V

15.3.1.3 non intrinsically safe transmitter supply circuits (terminals 7 and 9, 8 and 9, 10 and 12 and 11 and 12)

Nominal voltage		DC	28	V
Current			50	mA
Max. voltage	Um	AC/DC	125	V

Page 2 of 4 to BVS 05 ATEX E 124 X

This certificate may only be reproduced in its entirety and without change
 Dinnendahlstrasse 9 44809 Bochum Germany Phone +49 234/3696-105 Fax +49 234/3696-110



15.3.1.4	non intrinsically safe RS485 circuits (terminals 1 up to 6)				
	Nominal voltage		DC	6	V
	Current			100	mA
	Max. voltage	Um	AC/DC	48	V
15.3.1.5	intrinsically safe output circuits (terminals 1 – 4) type of protection EEx ib IIC				
	Us1 – GND, Us2 – GND				
	Voltage	Uo	DC	26	V
	Current	Io		58	mA
	RxD – GND				
	Voltage	Uo	DC	26	V
	Current	Io		8	mA
15.3.1.6	Ambient temperature range	Ta		-40 °C up to +65 °C	
15.3.2	Multiplexer Typ TTM 100A				
15.3.2.1	Transmitter supply circuits (terminals 20 up to 27)				
	type of protection EEx ia IIC				
	Voltage	Uo	DC	21,7	V
	Current	Io		90	mA
	Power	Po		584	mW
	Trapezoid output characteristic				
	Max. external capacitance	Co		148	nF
	Max. external inductance	Lo		4,3	mH
15.3.2.2	PT100 circuits 1 up to 8 (terminals A1 up to A18) and 9 up to 16 (terminals B1 up to B18)				
	type of protection EEx ia IIC				
	values for each terminal block				
	Voltage	Uo	DC	5,3	V
	Current	Io		13,7	mA
	Power	Po		23	mW
	Max. external capacitance	Co		3	µF
	Max. external inductance	Lo		50	mH
15.3.2.3	Ambient temperature range	Ta		-40 °C up to +65 °C	

(16) Test and assessment report
BVS PP 05.2092 EG as of 30.08.2005

(17) Special conditions for safe use

The permissible ambient temperature range for the transmitter type TTM 100B and for the multiplexer is -40 °C up to +65 °C. The use of the transmitter at an ambient temperature below -20 °C is only admissible, if the cables and cable entries are suitable for that temperature and use.



We confirm the correctness of the translation from the German original.
In the case of arbitration only the German wording shall be valid and binding.

44809 Bochum, 30. August 2005
BVS-Schu/Kw A 20050390

EXAM BBG Prüf- und Zertifizier GmbH

Certification body

Special services unit



1. Nachtrag

(Ergänzung gemäß Richtlinie 94/9/EG Anhang III Ziffer 6)

zur EG-Baumusterprüfbescheinigung BVS 05 ATEX E 124 X

Gerät: Temperatursensor- und Transmitter-Multiplexer Typ TTM 100*
Hersteller: IBS BatchControl GmbH
Anschrift: 50170 Kerpen

Beschreibung

Der Transmitter Typ TTM 100B kann auch nach den im zugehörigen Prüfprotokoll aufgeführten Prüfungsunterlagen gefertigt werden.

Die grundlegenden Sicherheits- und Gesundheitsanforderungen der geänderten Ausführung werden erfüllt durch Übereinstimmung mit

EN 50014:1997 + A1 – A2 Allgemeine Bestimmungen
 EN 50018:2000 +A1 Druckfeste Kapselung 'd'
 EN 50020:2002 Eigensicherheit 'i'

Die Kennzeichnung des Gerätes muss die folgenden Angaben enthalten:

II 2G EEx ib/ia IIC T4 für Typ TTM 100A
II 2G EEx d[ib] IIC T4 für Typ TTM 100B

Besondere Bedingungen für die sichere Anwendung bzw. Verwendungshinweise
 Unverändert

Kenngrößen

Transmitter Typ TTM 100B
 Netzstromkreis (Klemmen 18 und 19)
 Bemessungsspannung
 max. Spannung

Um	AC/DC	24	V
	AC/DC	250	V



Prüfprotokoll

BVS PP 05.2092 EG, Stand 11.11.2005

EXAM BBG Prüf- und Zertifizier GmbH
Bochum, den 11. November 2005



Zertifizierungsstelle



Fachbereich



1st Supplement

(Supplement in accordance with Directive 94/9/EC Annex III number 6)

to the EC-Type Examination Certificate BVS 05 ATEX E 124 X

Equipment: Temperature sensor multiplexer and Transmitter type TTM 100*
Manufacturer: IBS BatchControl GmbH
Address: 50170 Kerpen, Germany

Description

The transmitter type TTM 100B can be modified according to the descriptive documents as mentioned in the pertinent Test and Assessment Report.

The Essential Health and Safety Requirements of the modified equipment are assured by compliance with:

EN 50014:1997+A1-A2	General requirements
EN 50018:2000+A1	Flameproof enclosure 'd'
EN 50020:2002	Intrinsic safety 'i'

The marking of the equipment shall include the following:

 **II 2G EEx ib/ia IIC T4** for type TTM 100A
II 2G EEx d[ib] IIC T4 for type TTM 100B

Special conditions for safe use

Not changed

Parameters

Transmitter Typ TTM 100B

Mains circuit (terminals 18 and 19)

Nominal voltage

Max. voltage

Um

AC/DC	24	V
AC/DC	250	V



Test and assessment report
BVS PP 05.2092 EG as of 11.11.2005

EXAM BBG Prüf- und Zertifizier GmbH
Bochum, dated 11. November 2005

Signed: Dr. Jockers

Certification body

Signed: Dr. Eickhoff

Special services unit

We confirm the correctness of the translation from the German original.
In the case of arbitration only the German wording shall be valid and binding.

44809 Bochum, 11.11.2005
BVS-Schu/Mi A 20050313

EXAM BBG Prüf- und Zertifizier GmbH



Certification body



Special services unit



(1) 2. Nachtrag zur EG-Baumusterprüfbescheinigung

- (2) Geräte und Schutzsysteme zur bestimmungsgemäßen Verwendung in explosionsgefährdeten Bereichen - Richtlinie 94/9/EG
Ergänzung gemäß Anhang III Ziffer 6
- (3) Nr. der EG-Baumusterprüfbescheinigung: **BVS 05 ATEX E 124 X**
- (4) Gerät: **Temperatursensor- u. Transmitter-Multiplexer Typ TTM 100***
- (5) Hersteller: **IBS BatchControl GmbH**
- (6) Anschrift: **50170 Kerpen**
- (7) Die Bauart dieser Geräte sowie die verschiedenen zulässigen Ausführungen sind in der Anlage zu diesem Nachtrag festgelegt.
- (8) Die Zertifizierungsstelle der DEKRA EXAM GmbH, benannte Stelle Nr. 0158 gemäß Artikel 9 der Richtlinie 94/9/EG des Europäischen Parlaments und des Rates vom 23. März 1994, bescheinigt, dass diese Geräte die grundlegenden Sicherheits- und Gesundheitsanforderungen für die Konzeption und den Bau von Geräten und Schutzsystemen zur bestimmungsgemäßen Verwendung in explosionsgefährdeten Bereichen gemäß Anhang II der Richtlinie erfüllen. Die Ergebnisse der Prüfung sind in dem Prüfprotokoll BVS-PP 05.2092 EG niedergelegt.
- (9) Die grundlegenden Sicherheits- und Gesundheitsanforderungen werden erfüllt durch Übereinstimmung mit:
- EN 60079-0:2009 Allgemeine Anforderungen**
EN 60079-1:2007 Druckfeste Kapselung 'd'
EN 60079-11:2007 Eingensicherheit 'i'
- (10) Falls das Zeichen "X" hinter der Bescheinigungsnummer steht, wird in der Anlage zu dieser Bescheinigung auf besondere Bedingungen für die sichere Anwendung des Gerätes hingewiesen.
- (11) Dieser Nachtrag zur EG-Baumusterprüfbescheinigung bezieht sich nur auf die Konzeption und die Baumusterprüfung der beschriebenen Geräte in Übereinstimmung mit der Richtlinie 94/9/EG. Für Herstellung und Inverkehrbringen der Geräte sind weitere Anforderungen der Richtlinie zu erfüllen, die nicht durch diese Bescheinigung abgedeckt sind.
- (12) Die Kennzeichnung des Gerätes muss die folgenden Angaben enthalten:

II 2G Ex ib[ia] IIC T4 Gb für Typ TTM 100A
II 2G Ex d[ib] IIC T4 Gb für Typ TTM 100B



oder

II 2G Ex ib[ia] IIC T4 für Typ TTM 100A
II 2G Ex db[ib] IIC T4 für Typ TTM 100B

DEKRA EXAM GmbH
 Bochum, den 13.10.2011



 Zertifizierungsstelle



 Fachbereich

Seite 1 von 3 zu BVS 05 ATEX E 124 X / N2
 Dieses Zertifikat darf nur vollständig und unverändert weiterverbreitet werden.
 DEKRA EXAM GmbH, Diemelstraße 9, 44809 Bochum, Telefon +49 234 3666-305, Telefax +49 234 3695-110, zs-exam@dekra.com



- (13) Anlage zum
- (14) **2. Nachtrag zur EG-Baumusterprüfbescheinigung
BVS 05 ATEX E 124 X**
- (15) **15.1 Gegenstand und Typ**

Temperatursensor- u. Transmitter-Multiplexer Typ TTM 100*

Anstelle des * wird in der vollständigen Benennung der Buchstabe A oder B eingefügt, der unterschiedliche Gehäuse kennzeichnet.

15.2 Beschreibung

Es wurden verschiedene Änderungen an eigensicherheitsrelevanten Bauteilen, sowie an Teilen der nicht eigensicheren Elektronik vorgenommen.

Zu dem wird die Übereinstimmung mit dem Normen EN 60079-0:2009, EN 60079-1:2007 und EN 60079-11:2007 bestätigt.

15.3 Kenngrößen

15.3.1 Transmitter Typ TTM 100B

15.3.1.1 Netzstromkreis (Klemmen 18 und 19)

Bemessungsspannung		AC	115	V
Max. Spannung	Um	AC/DC	125	V
oder				
Bemessungsspannung		AC	230	V
Max. Spannung	Um	AC/DC	250	V
oder				
Bemessungsspannung		AC/DC	24	V
Max. Spannung	Um	AC/DC	250	V

15.3.1.2 Nicht eigensichere Relaiskontakt-Stromkreise (Klemmen 13 und 14 und 15 und 16)

Schaltspannung		DC	30	V
Schaltstromstärke			1	A
oder				
Schaltspannung		AC	125	V
Schaltstromstärke			0,5	A
Max. Spannung	Um	AC/DC	125	V

15.3.1.3 Nicht eigens. Transmitter-Speisestromkreise (Klemmen 7 und 9, 8 und 9, 10 und 12, 11 und 12)

Bemessungsspannung		DC	28	V
Stromstärke			50	mA
Max. Spannung	Um	AC/DC	125	V

15.3.1.4 Nicht eigensichere RS485-Schnittstelle (Klemmen 1 bis 6)

Bemessungsspannung		DC	6	V
Stromstärke			100	mA
Max. Spannung	Um	AC/DC	48	V

15.3.1.5 Eigensichere Ausgangstromkreise (Klemmen 1 – 4) in der Zündschutzart Ex Ib IIC

Us1 – GND, Us2 – GND				
Max. Ausgangsspannung	Uo	DC	28	V
Max. Ausgangsstromstärke	Io		58	mA
RxD – GND				
Max. Ausgangsspannung	Uo	DC	28	V
Max. Ausgangsstromstärke	Io		8	mA

Seite 2 von 3 zu BVS 05 ATEX E 124 X I MZ
Dieses Zertifikat darf nur vollständig und unverändert weiterverbreitet werden.
DEKRA EXAM GmbH, Ohmstraße 9, 44609 Bochum, Telefon +49 234 3696-105, Telefax +49 234 3996-110, zs-exam@dekra.com



15.3.1.8	Umgebungstemperaturbereich	Ta		-40 °C bis +65 °C
15.3.2	Multiplexer Typ TTM 100A - Multiplexer type TTM 100A			
15.3.2.1	Transmitterspeisestromkreise in der Zündschutzart Ex ia IIC (Klemmen 20 bis 27)			
	Max. Ausgangsspannung	Uo	DC	21,7 V
	Max. Ausgangsstromstärke	Io		90 mA
	Max. Ausgangsleistung	Po		584 mW
	Trapezförmige Ausgangskennlinie			
	Max. äußere Kapazität	Co		148 nF
	Max. äußere Induktivität	Lo		4,3 mH
15.3.2.2	PT100-Stromkreise 1 bis 8 (Klemmen A1 bis A18) und 9 bis 16 (Klemmen B1 bis B18) in der Zündschutzart Ex ia IIC			
	Werte je Klemmenblock			
	Max. Ausgangsspannung	Uo	DC	5,3 V
	Max. Ausgangsstromstärke	Io		13,7 mA
	Max. Ausgangsleistung	Po		23 mW
	Max. äußere Kapazität	Co		3 µF
	Max. äußere Induktivität	Lo		60 mH
15.3.2.3	Umgebungstemperaturbereich	Ta		-40 °C bis +65 °C

(16) Prüfprotokoll

BVS PP 05.2092 EG, Stand 13.10.2011

(17) Besondere Bedingungen für die sichere Anwendung

Der zulässige Umgebungstemperaturbereich für den Betrieb des Transmitters Typ TTM 100B und des Multiplexers Typ TTM 100A ist -40 °C bis +65 °C. Die Verwendung der Geräte in einer Umgebungstemperatur unter -20 °C ist zulässig, wenn für diese Temperatur geeignete Leitungen und für diesen Einsatz geeignete Kabel- oder Leitungseinführungen verwendet werden.



Translation

2. Supplement to the EC-Type Examination Certificate

- (2) Equipment and protective systems intended for use in potentially explosive atmospheres - Directive 94/9/EC Supplement accordant with Annex III number 6
- (3) No. of EC-Type Examination Certificate: **BVS 05 ATEX E 124 X**
- (4) Equipment: **Temperature sensor multiplexer and Transmitter type TTM 100***
- (5) Manufacturer: **IBS BatchControl GmbH**
- (6) Address: **50170 Kerpen, Germany**
- (7) The design and construction of this equipment and any acceptable variation thereto are specified in the appendix to this supplement.
- (8) The certification body of DEKRA EXAM GmbH, notified body no. 0158 in accordance with Article 9 of the Directive 94/9/EC of the European Parliament and the Council of 23 March 1994, certifies that this equipment has been found to comply with the Essential Health and Safety Requirements relating to the design and construction of equipment and protective systems intended for use in potentially explosive atmospheres, given in Annex II to the Directive. The examination and test results are recorded in the test and assessment report BVS-PP 05.2092 EG.
- (9) The Essential Health and Safety Requirements are assured by compliance with:
EN 60079-0:2009 General requirements
EN 60079-1:2007 Flameproof Enclosure 'd'
EN 60079-11:2007 Intrinsic Safety 'i'
- (10) If the sign "X" is placed after the certificate number, it indicates that the equipment is subject to special conditions for safe use specified in the appendix to this certificate.
- (11) This supplement to the EC-Type Examination Certificate relates only to the design, examination and tests of the specified equipment in accordance to Directive 94/9/EC. Further requirements of the Directive apply to the manufacturing process and supply of this equipment. These are not covered by this certificate.
- (12) The marking of the equipment shall include the following:

II 2G Ex ib[ia] IIC T4 Gb for type TTM 100A
II 2G Ex d[ib] IIC T4 Gb for type TTM 100B



II 2G Ex ib[ia] IIC T4 for type TTM 100A
II 2G Ex db[ib] IIC T4 for type TTM 100B

DEKRA EXAM GmbH
 Bochum, dated 13.10.2011

Signed: Simanski

Signed: Dr. Eickhoff

Certification body

Special services unit



(13) Appendix to

(14) **2. Supplement to the EC-Type Examination Certificate
BVS 05 ATEX E 124 X**

(15) 15.1 Subject and type

Temperature sensor multiplexer and Transmitter type TTM 100*

Instead of the * in the complete denomination the letter A or B will be inserted to characterize different apparatus.

15.2 Description

Several changes to intrinsically safe relevant components and to parts of the non intrinsically safe electronic have been accomplished.

Beside these changes the compliance with the standards EN 60079-0 :2009, EN 60079-1 :2007 and EN 60079-11:2007 is certified.

15.3 Parameters

15.3.1 Transmitter Type TTM 100B

15.3.1.1 Mains circuit (terminals 18 and 19)

Nominal voltage		AC	115	V
Maximum voltage	Um	AC/DC	125	V
or				
Nominal voltage		AC	230	V
Maximum voltage	Um	AC/DC	250	V
or				
Nominal voltage		AC/DC	24	V
Maximum voltage	Um	AC/DC	250	V

15.3.1.2 Non intrinsically safe relay contact (terminals 13 and 14 and 15 and 16)

Switching voltage		DC	30	V
Switching current			1	A
or				
Switching voltage		AC	125	V
Switching current			0,5	A
Maximum voltage	Um	AC/DC	125	V

15.3.1.3 Non intrinsically safe transmitter supply circuits (terminals 7 and 9, 8 and 9, 10 and 12, 11 and 12)

Nominal voltage		DC	28	V
Current			50	mA
Maximum voltage	Um	AC/DC	125	V

15.3.1.4 Non intrinsically safe RS485 circuits (terminals 1 up to 6)

Nominal voltage		DC	6	V
Current			100	mA
Maximum voltage	Um	AC/DC	48	V

15.3.1.5 Intrinsically safe output circuits (terminals 1 – 4) type of protection Ex ib IIC

Us1 – GND, Us2 – GND				
Maximum output voltage	Uo	DC	26	V
Maximum output current	Io		58	mA
RxD – GND				
Maximum output voltage	Uo	DC	26	V
Maximum output current	Io		8	mA

Page 2 of 3 to BVS 05 ATEX E 124 X / N2

This certificate may only be reproduced in its entirety and without change.

DEKRA EXAM GmbH, Drivendahlstrasse 9, 44999 Bochum, Phone +49.234.3999-105, Fax +49.234.3999-110, ze-exam@dekra.com



15.3.1.6	Ambient temperature range	Ta		-40 °C up to +65 °C
15.3.2	Multiplexer Type TTM 100A			
15.3.2.1	Transmitter supply circuits (terminals 20 up to 27)			
	Type of protection EEx ia IIC			
	Maximum output voltage	Uo	DC	21.7 V
	Maximum output current	Io		90 mA
	Maximum output power	Po		584 mW
	Trapezoid output characteristic			
	Maximum external capacitance	Co		148 nF
	Maximum external inductance	Lo		4.3 mH
15.3.2.2	PT100 circuits 1 up to 8 (terminals A1 up to A18) and 9 up to 16 (terminals B1 up to B18)			
	type of protection Ex ia IIC			
	Values for each terminal block			
	Maximum output voltage	Uo	DC	5.3 V
	Maximum output current	Io		13.7 mA
	Maximum output power	Po		23 mW
	Maximum external capacitance	Co		3 µF
	Maximum external inductance	Lo		50 mH
15.3.2.3	Ambient temperature range	Ta		-40 °C up to +65 °C

(16) Test and assessment report
BVS PP 05.2092 EG as of 13.10.2011

(17) Special conditions for safe use
The permissible ambient temperature range of the transmitter type TTM 100B and of the multiplexer type TTM 100A is -40 °C up to +65 °C. The use of the equipments at an ambient temperature below -20 °C is only admissible, if the cables and cable entries are suitable for that temperature and use.

We confirm the correctness of the translation from the German original.
In the case of arbitration only the German wording shall be valid and binding.

DEKRA EXAM GmbH
44809 Bochum, 13.10.2011
BVS-Ste/Her A 20110509



Certification body



Special services unit