

BC 20 batch controller for simple applications



- 24 VDC and 100-240 VAC version available
- For non-Ex applications
- Easy operation via a numeric keyboard
- 2-line back lighted display, character size: 5,5 mm
- Size 96 x 96 x 120 mm
- Indication:
 - Pre-set value
 - Batched quantity
 - Batch status
 - Actual flow rate
 - Error messages
- Intelligent overfilling and under batch correction

Intelligent Batch Solutions.....designed for you

Block diagram:

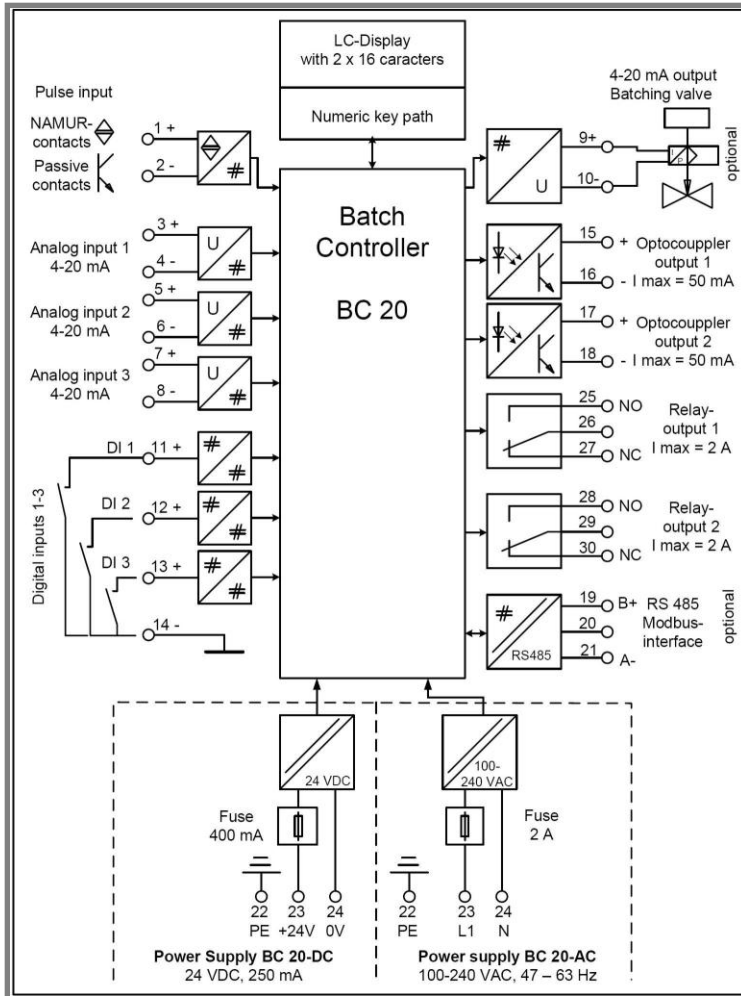

Two versions are available:

- BC 20-DC with 24 VDC power supply
- BC 20-AC with 100-240 VAC power supply

Optional functions:

- 4-20 mA output to the batching valve with ramping functions
- 4-20 mA output for the batching valve with additional PID flow control function
- RS 485 Modbus interface for the communication to a supervisory system

Flow signal input possibilities:

- 4-20 mA
- passive pulses
- Inductive sensors (NAMUR contacts)

Batching valve control possibilities:

One On/Off batching valve:

The solenoid of the batching valve can be switched by a relay output of the BC 20. Changes of product velocity and pressure could cause over run or under batch quantities. For the reducing of these effects the BC 20 has an intelligent, self optimizing overrun and under batch correction function available.

Two On/Off batching valves parallel:

The two solenoids of the batching valves can be switched via the two relay outputs of the BC 20.

The larger valve closes at a programmed quantity before the end and the exact switch-off is realized by the smaller valve which switches at the end of the batch.

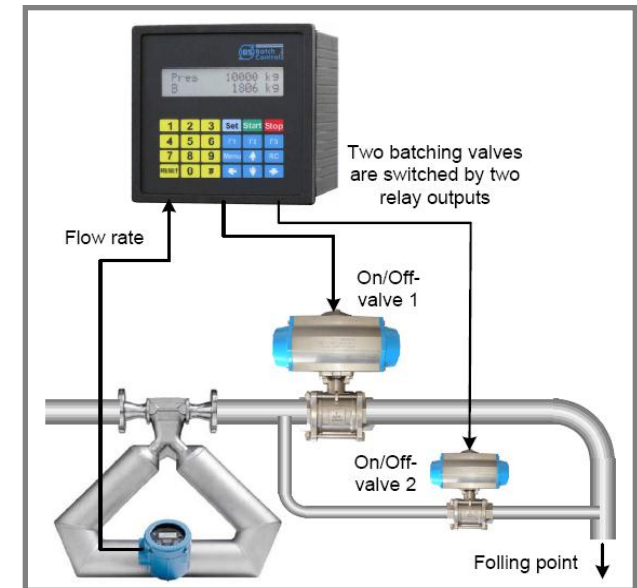
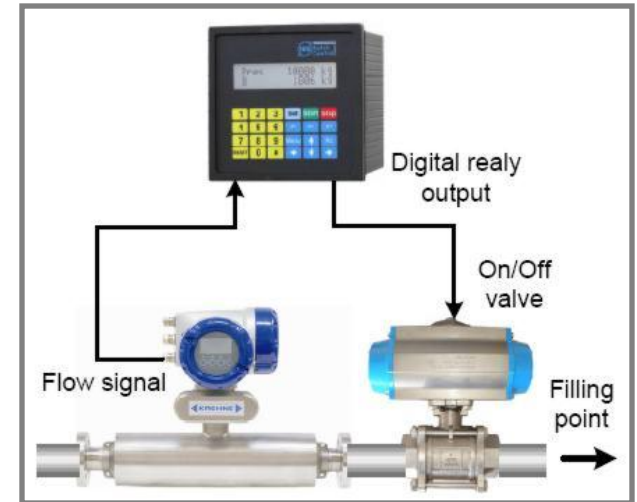

PID flow control function (optional)

Via the 4-20 mA output signal of the BC 20 it's possible to control the flow rate during the batch process.



SP 20000 kg/h
PV 19990 kg/h

Modbus communication (optional)

A DCS system is able to read out the information of the actual batch process and also the results from the last batch for the report.

Preset values and parameters can be written from the DCS to the BC 20.

Via the "terminal function" the BC 20 can be used as a HMI between the user and the DCS.



CODE: *****
PLEASE ENTER!



EARTH CONNECTED?
F1=OK F3=ABORT

Purge functions

For the filling or cleaning of the measuring system different purge functions are available. They can be activated by the function key F1, by a digital input or optional for a programmed time.



Pres 20000 kg
Purge

Error messages in clear text

The BC 20 has different safety- and monitoring functions. In case of a failure message the batch will be stopped immediately. After resetting the message, the batch can be continued via the start button.

Low flow rate monitoring

If the flow rate during the batch is too low, the batch will be stopped after a programmed time. This function prevent a unregulated filling in case of a failure in the system.

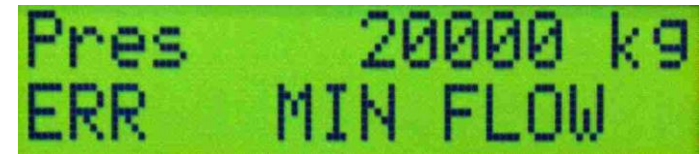

Pres 20000 kg
ERR MIN FLOW

Two release signals

Two custom specific release signals can be switched via digital inputs. The message texts can be changed in the programming menu.



Pres 20000 kg
ERR.L-MAX TANKER

Sensor failure monitoring

The BC 20 has a sensor break and a measuring range overrun monitoring function for the 4-20 mA input and if inductive contacts (NAMUR contacts) are connected to the pulse input.



Pres 20000 kg
ERR.NO GROUNDING

Complete batch systems:

IBS BatchControl offers complete batch systems (turn key projects)

Consisting of:

- System layout based on the process data and the required accuracy.
- Selection of the pumps, flow meters, batching valves and additional process instruments.
- Delivery of the batch controllers
- Building of control panels
- Design and detailed engineering like installation and connection diagrams
- Mechanical and electrical installations of the process instruments
- Start-up of the system
- After sales service like periodic maintenances and accuracy tests



Order codes and technical data:

BC 20-DC (Order code 500-0110)

Panel mount housing 96 x 96 x 120 mm
Back lighted LC-display, 2 x 16 characters
Power supply 24 VDC
3 x Analogue input, 4-20 mA, passive
1 x Pulse input, active
3 x Digital input, active
2 x Optocoupler output, passive, I_{max} = 50 mA
2 x Relay output, passive, I_{max}= 3A, U_{max}= 250V
1 x Valve output signal, 4-20 mA, active, optional
1 x RS485 interface with Modbus protocol, optional

BC 20-AC (Order code 500-0120)

Panel mount housing 96 x 96 x 120 mm
Back lighted LC-display, 2 x 16 characters
Power supply 85-240 VAC, 47-63Hz
3 x Analogue input, 4-20 mA, passive
1 x Pulse input, active
3 x Digital input, active
2 x Optocoupler output, passive, I_{max} = 50 mA
2 x Relay output, passive, I_{max}= 3A, U_{max}= 250V
1 x Valve output signal, 4-20 mA, active, optional
1 x RS485 interface with Modbus protocol, optional

Software options:

500-0130

Valve output signal 4-20 mA, active

With start-up ramp and 5-step shut-off ramp

500-0140

Valve output signal with PID flow control function

PID control function for the flow rate control during the batch

Price includes the option 500-0130 .

500-0150

RS485 interface with Modbus protocol

Some main customers:

3M, France, Germany

Abbot, USA, Germany

Air Liquide, France, Germany,

Aker Kvaerner, The Netherlands

Akzo Nobel, China, The Netherlands, Germany

Arkema, France, Germany

Astra Zeneca, England

BASF, Belgium, Malaysia, Mexico, China, Germany

Bayer, Malaysia, Spain, Vietnam, Germany

Basell, Germany

British American Tobacco, Germany

Butagaz, France

Clariant, China, Greece, Switzerland, Germany

Ciba, Italy, France, Switzerland, Germany

Christ Water Technology, Germany

Cognis, Germany

Degussa, Belgium, Germany

Dupont, Germany

DSM, Austria, Germany, The Netherlands,

Endress + Hauser, worldwide

Emerson, worldwide

Exxon, France, The Netherlands

GlaxoSmithKline, Great Britain, Italy

Kraus Global, Kanada, Korea

Krohne Messtechnik, worldwide

Lanxess, Germany

Linde, Germany

Lukoil, Ukraine

Lurgi, Germany

Merck, Germany

Novartis, Switzerland, Germany

Oiltanking, Belgium

Oval Asia, Singapore

Petrobras, Brazil

Petronas, Malaysia

Rhodia, France, Germany

Roche, Switzerland, Germany

Sanofi-Aventis, France, Germany

Sipchem, Saudi Arabia

Shell, Germany

Symrise, Germany

Tecnicas Reunidas, Spain

Total, France

Toyo Engineering, Japan

Uhde, China, Iran, Egypt, Ukraine, Germany

Vopak Banyan Terminals, Singapore

Wacker Chemie, China, India, Germany

Intelligent Batch Solutions.....designed for you



Exi Indicators



Exi Controllers



Exi and non-Ex
Batch Controllers



Exi Interfaces



Exi Recorders



IBS BatchControl GmbH
50170 Kerpen /Germany
www.ibs-batchcontrol.de



Flow Computers